

Manual - ValkScreenVision 1.0



Upper Screen

		page
Table of contents		1
Disclaimer		2
Mounting gable components	Screen plates (55mm)	A1 - 3
ValkReversingWheel section separation	ValkReversingWheel - 2 per trellis	B1 - 3
Mounting ValkBearingBracket	ValkBearingBracket - Drilled	C1 - 4
Mounting ValkDriveTube	ValkDriveTube X-Reduced	D1
Mounting ValkScreenProfile	ValkScreenVision 1.0 profile	E1
Measure row ValkTrussClips	Standard ValkTrussClips with VSV 1.0	F1
Polyester wires	Polyester wires to screen plate - With black coated steel wire	G1 - 2
Pull wire	Pull wire	H1 - 4
Return wire pulley (ValkPulley)	ValkPulley attached to VSV screen profile	I1
ValkTrussClips	Standard ValkTrussClips with VSV 1.0	J1
Screen cloth pull rope	Screen cloth pull rope	K1
ValkKliMax Slide	VSV	L1
Coupling ValkScreenProfiles	VSV 1.0 profile	M1
ValkWireGuide	ValkScreenVision	N1
ValkScreenClip	N/A	O1
ValkKliMax	VSV	P1
Retraction of screen cloth	VSV 1.0	Q1
Screen cloth hangdown	Cloth Hangdown - VSV 1.0	R1 - 5

You have chosen a screen system from Van der Valk horti systems. This manual is a standard manual for specific installation drawings, see project drawings and quotation supplied separately. If you see a QR code in the manual, a movie is available with additional explanation. You can watch this movie by scanning the QR code.

- * This manual is not project specific.
- * This manual is not legally binding.
- * No right may be derived from this installation manual.
- * Consult the cloth and motor supplier manual for installation of their products.



if you scan or click this QR-code you will be linked to the youtube playlist of all installation movies. you will find a specific QR-code at the page.

▶ Mounting screen plate

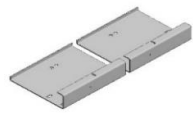
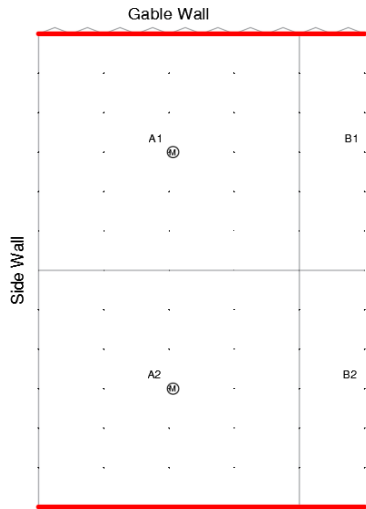

50.7-.055.----



55.40.20 M8x20



55.40.05 M8



53.55.17 M8



55.30.16 M6x16



55.30.00 M6

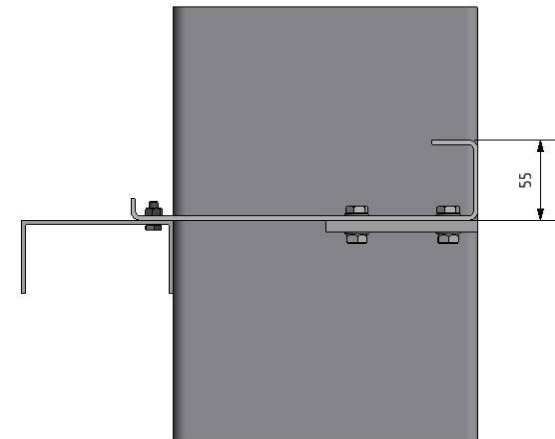
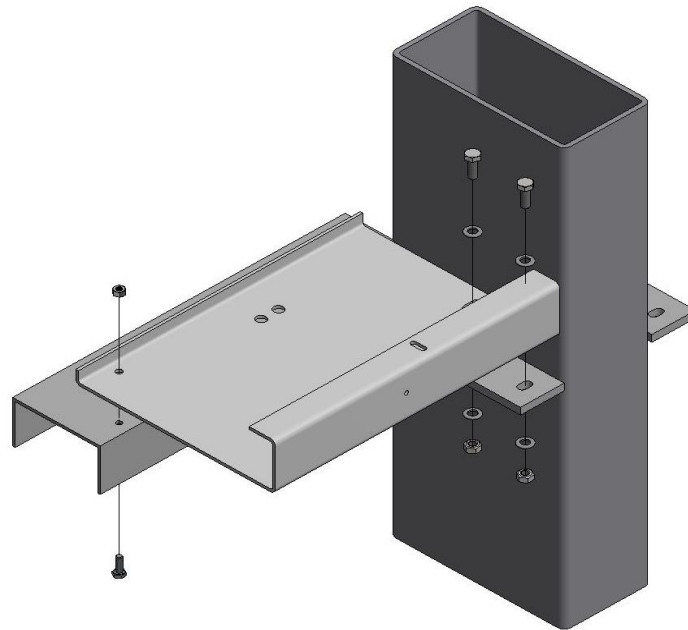

Note: The top of the screen strip is equal to the bottom of the trellis top chord.

▶ Atlas wire clip

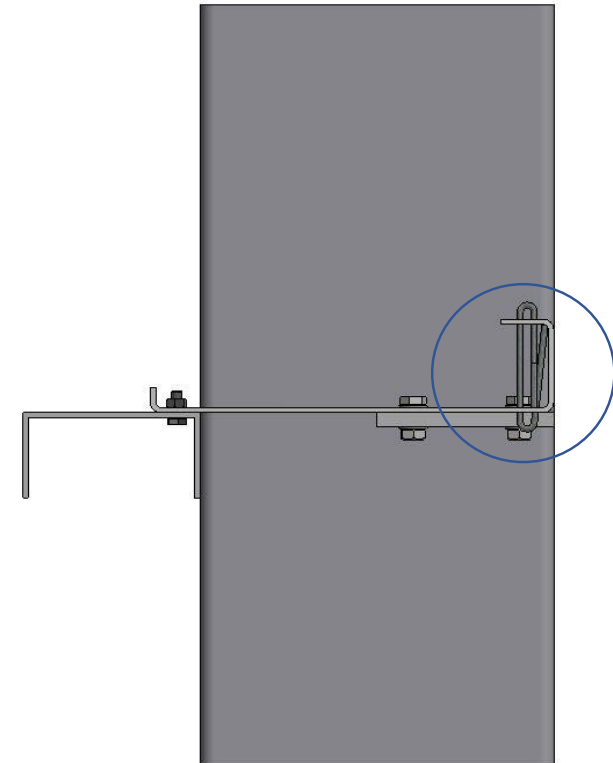
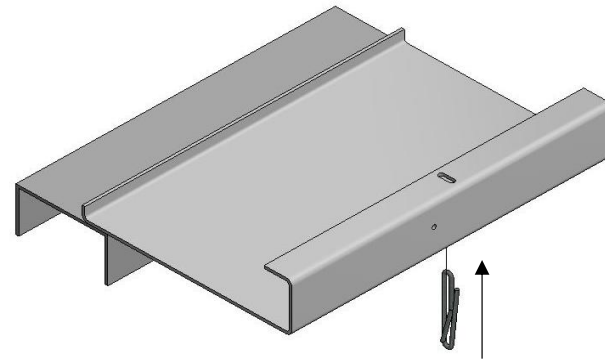
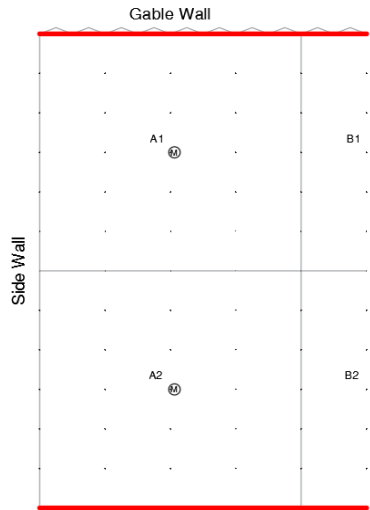

45.81.85

▶ ValkReversingWheel for screen plate

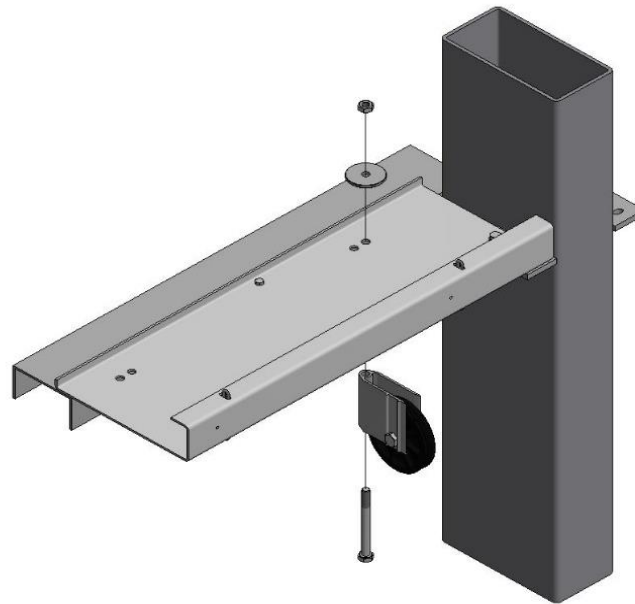
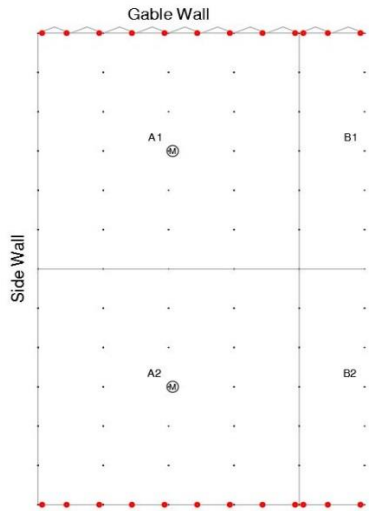

The screen plates are produced with 2 holes for the reversing wheels. Use 1 of the 2 holes.

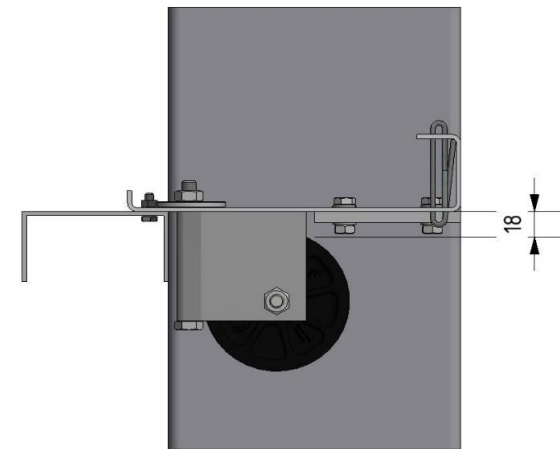

Note: When using the wire clip, the distance between the bottom of the screen plate and the pull wire is 18 mm.



44.81.30



55.51.00 M10x100



53.55.42 M10



55.50.00 M10

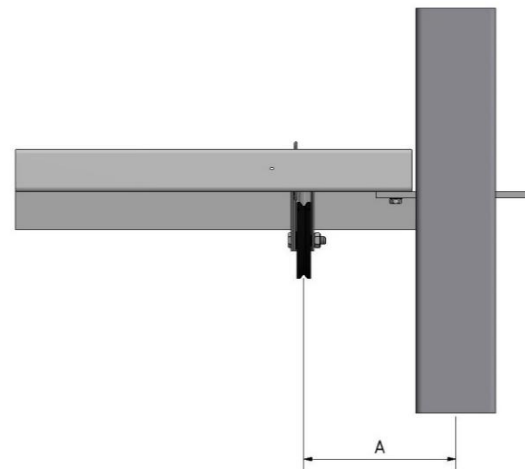

For size A, see project specific file.

ValkReversingWheel Double

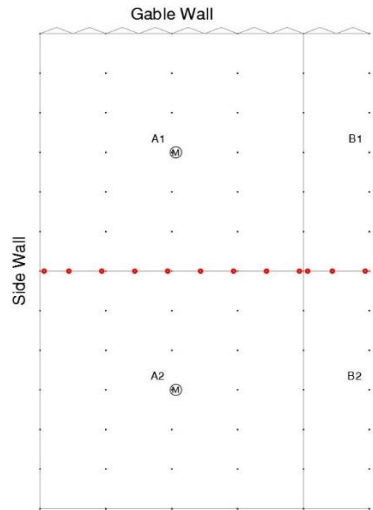

Mount the bolt heads on the package side of the screen.

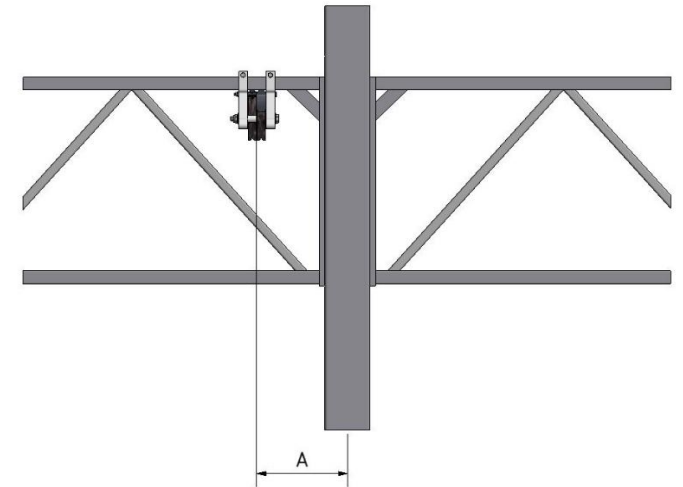
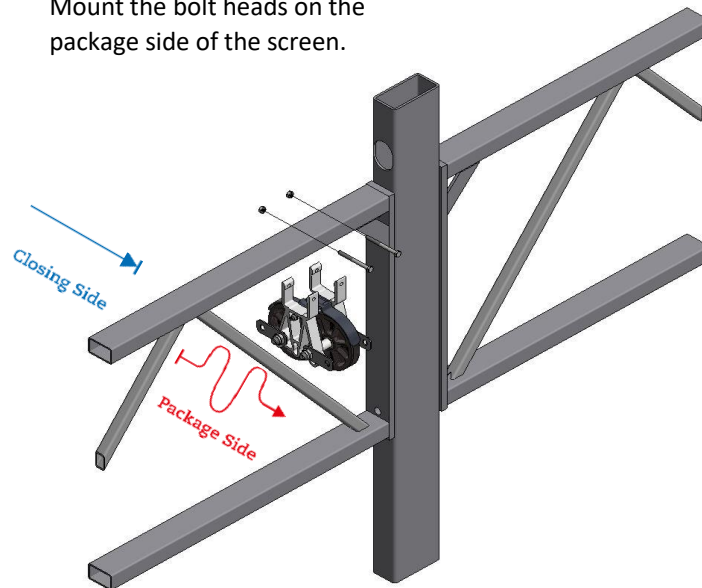

For size A, see project specific file.



(topcord width and height)
44.740.---.--- black
(topcord width and height)
44.740.---.--- gray



(trellis width + 15 mm)
55.30.--



55.30.00

▶ Bracing of ValkReversingWheel Double

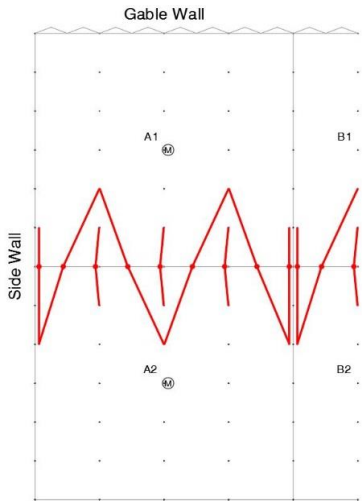

Bracing at the column:

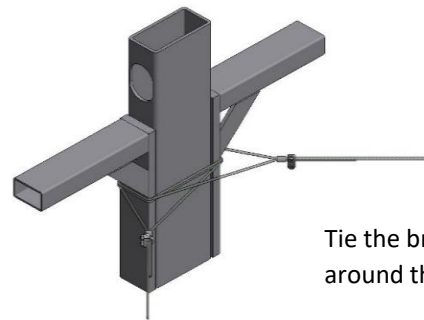

Tie the bracing wire around the column.

Brace diagonally when the reversing wheel is close to the middle of the trellis.

Brace straight when the reversing wheel is close to the column.

Floating gutter:

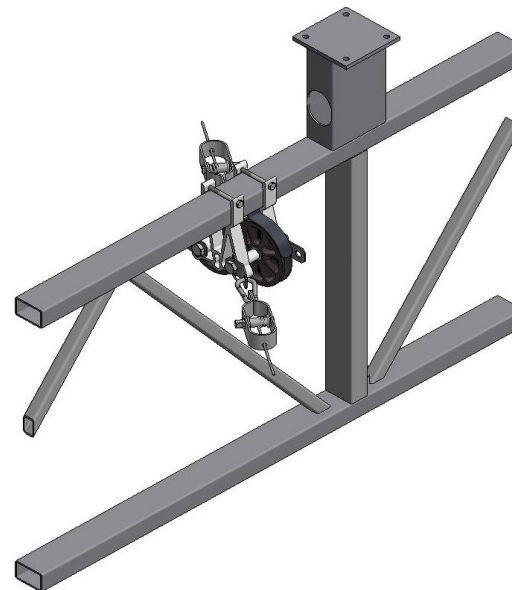

Column.

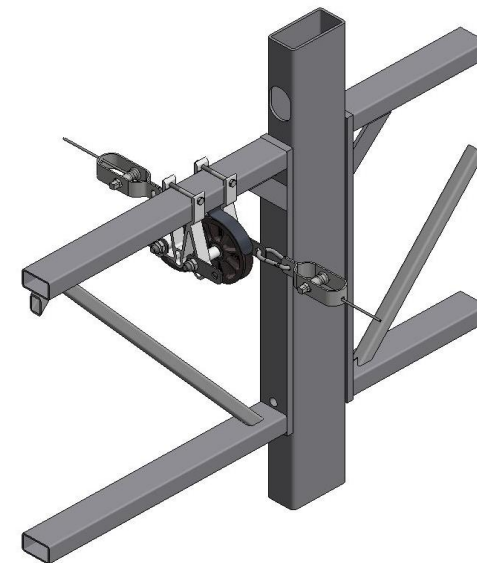

41.10.17



48.80.40



48.80.12



48.80.30



48.80.37

▶ Bracing of ValkReversingWheel at section ends

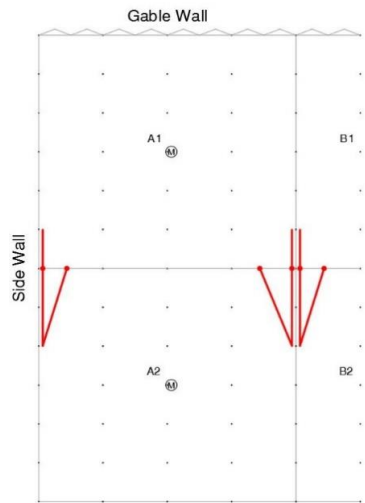

Mount the bearing plate opposite to the pulling side of the bracing wire.

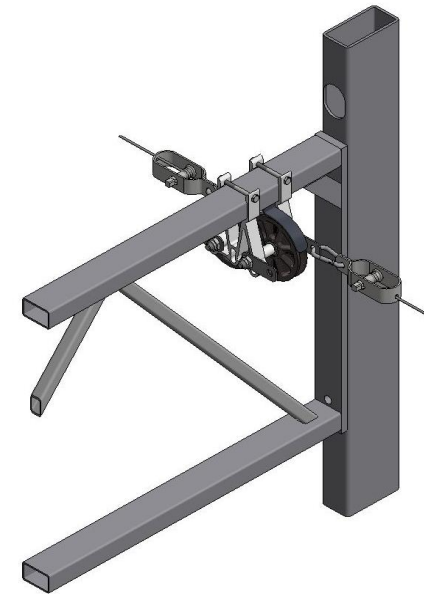
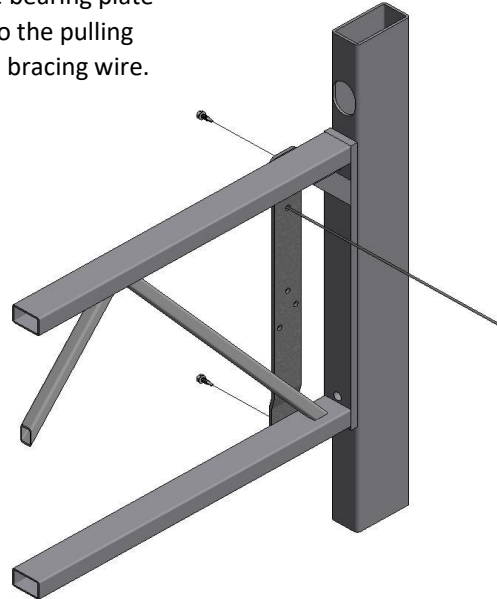

(trellis height)
44.82.10.----



53.57.20

▶ ValkBearingBracket (2") at the column

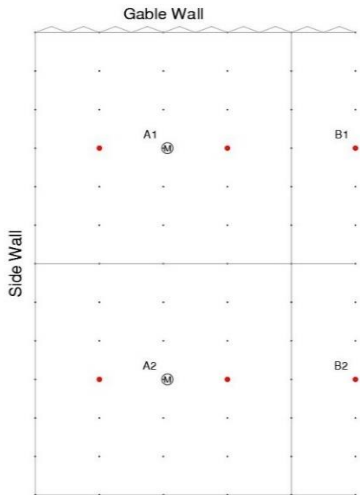

44.82.14



(Column width + 20 mm)
55.40.-- M8x--



55.40.00 M8



53.55.17 M8

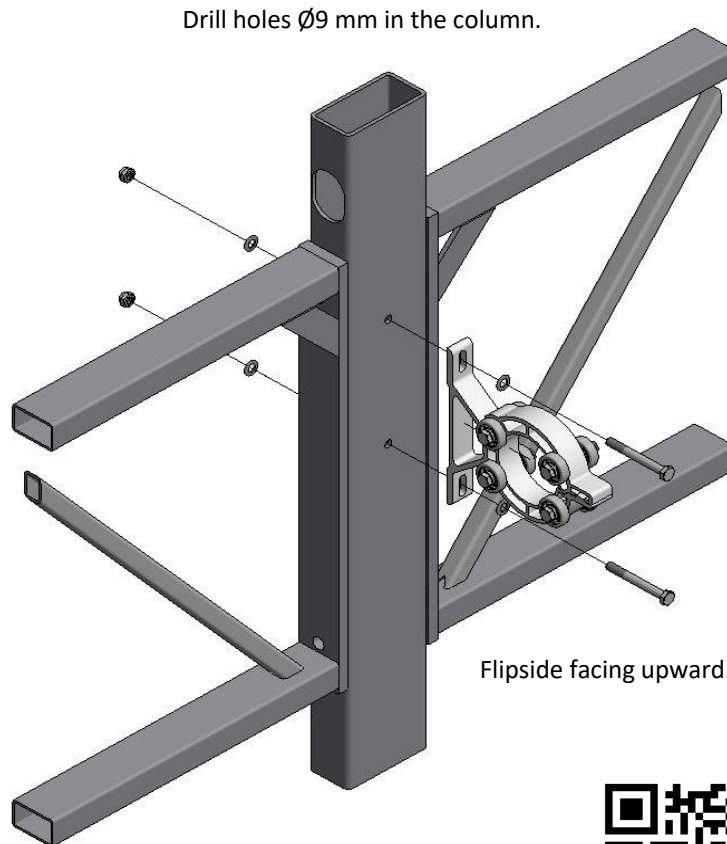

Flipside facing upward.

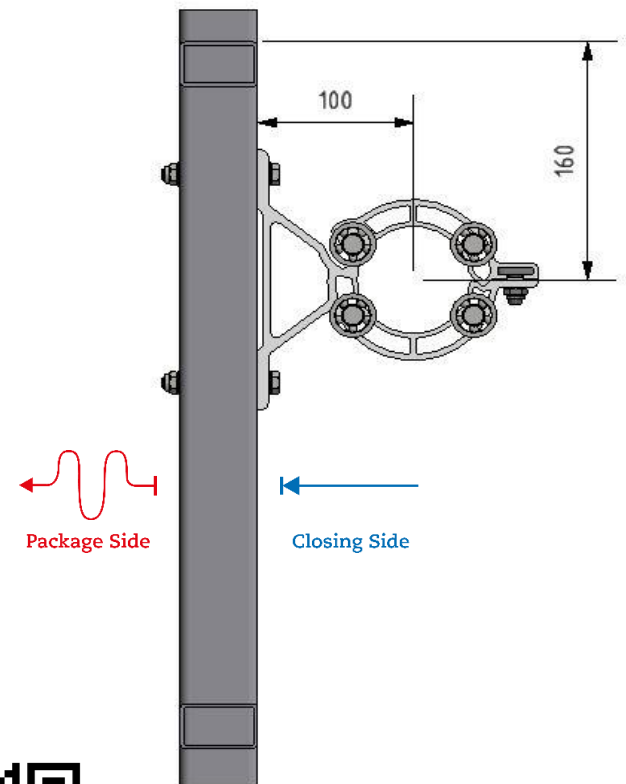

▶ ValkBearingBracket (2") at the floating gutter

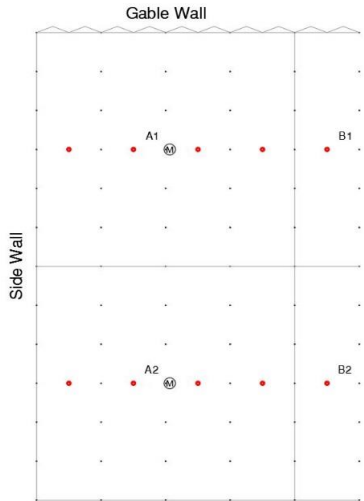

Drill holes $\varnothing 9$ mm in the tube.

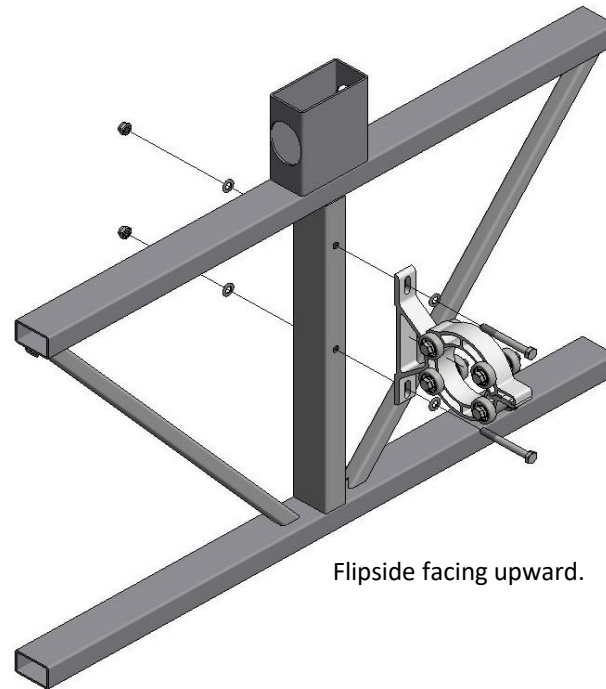

Flipside facing upward.



44.82.14



(Column width + 20 mm)
55.40.-- M8x--



55.40.00 M8



53.55.17 M8

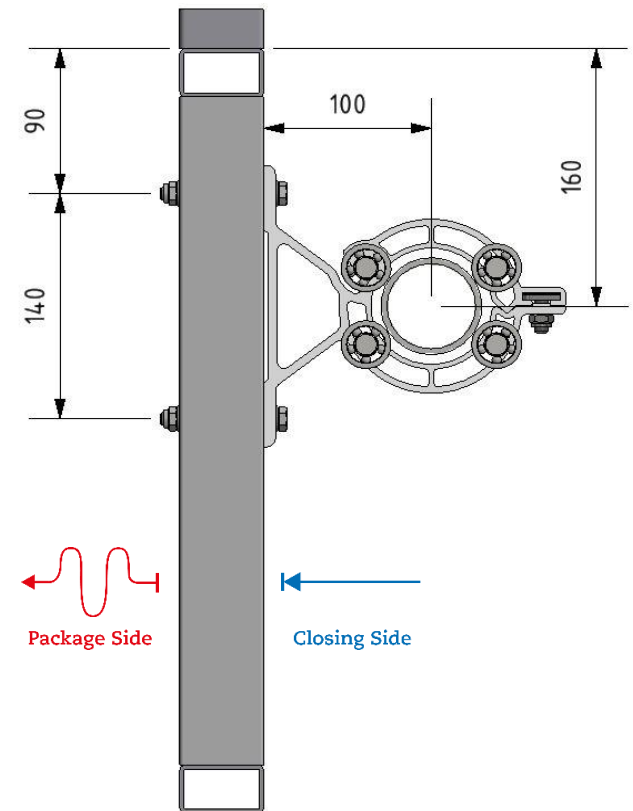

Package Side

Closing Side

▶ ValkBearingBracket (2") at the section end

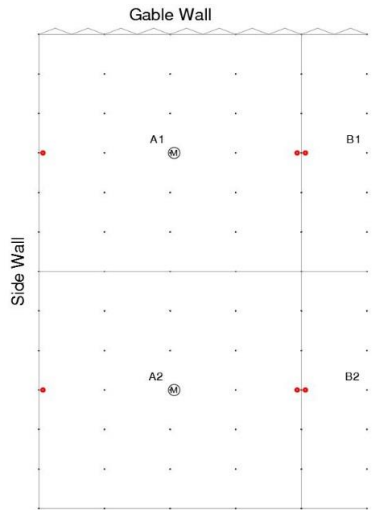

Drill holes $\varnothing 9$ mm in the tube 15 mm below the top of the tube.

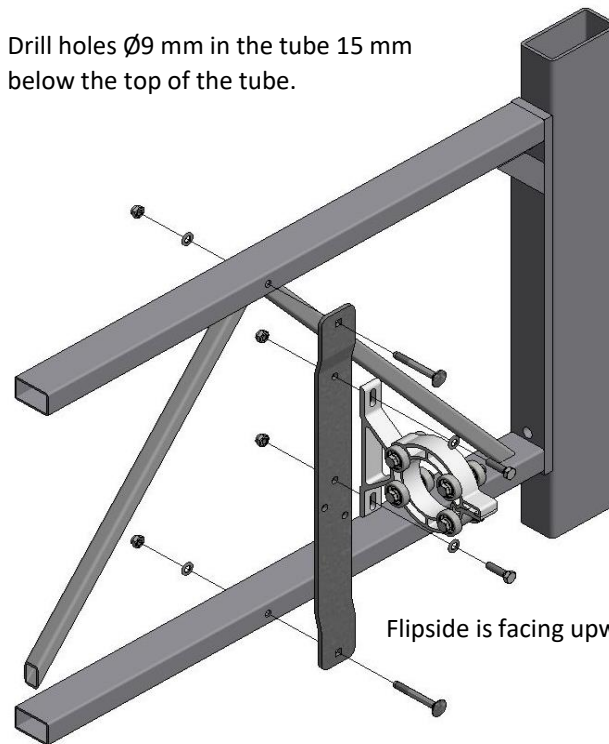

Drill holes $\varnothing 9$ mm in the tube 15 mm above the bottom of the tube.

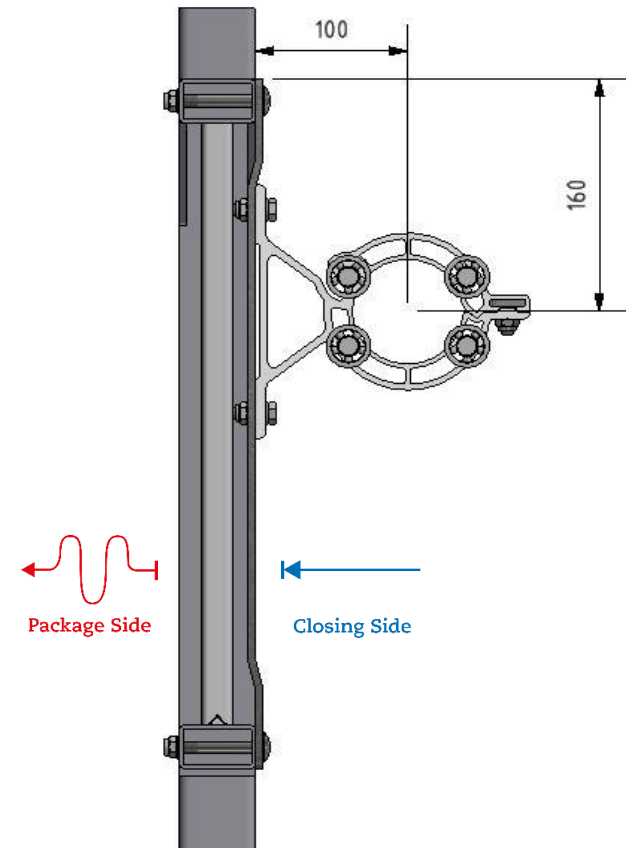

44.82.14

(trellis height)

44.82.10.----

(trellis width +15 mm)

53.41.-- M8x--

55.40.30 M8x30

53.55.17 M8

55.40.00 M8

▶ Bracing the ValkBearingBracket at the floating gutter

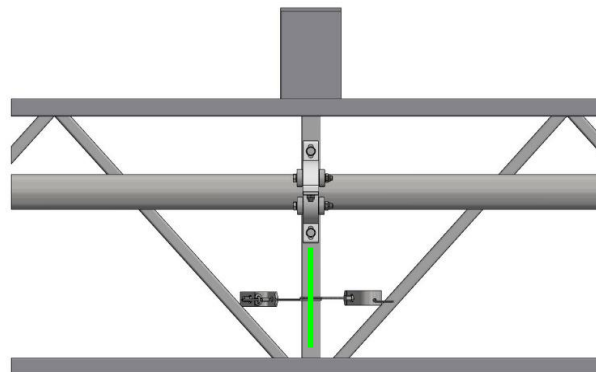
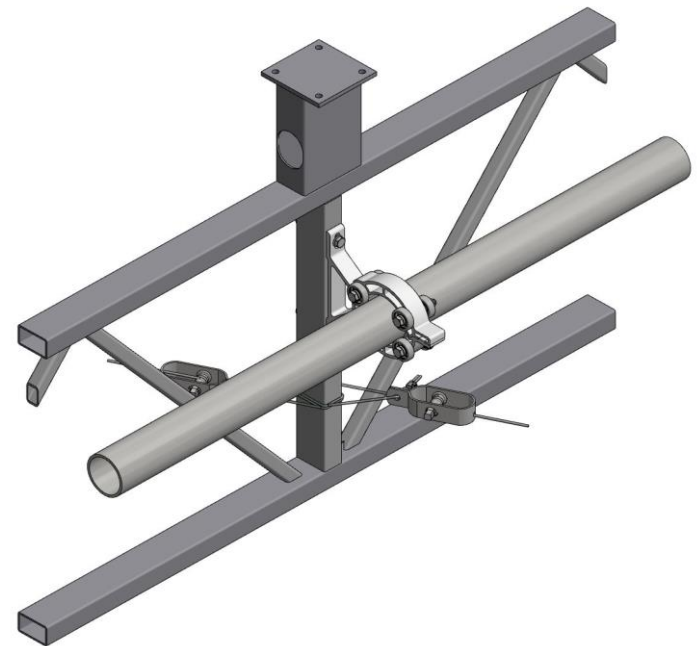
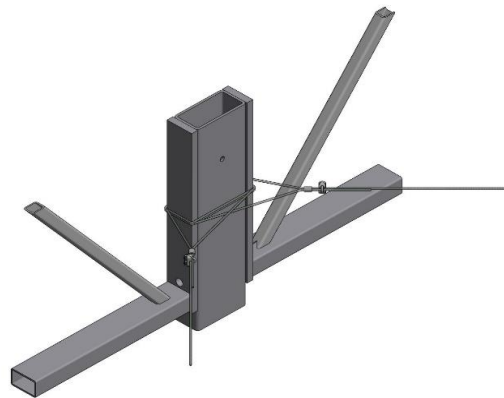
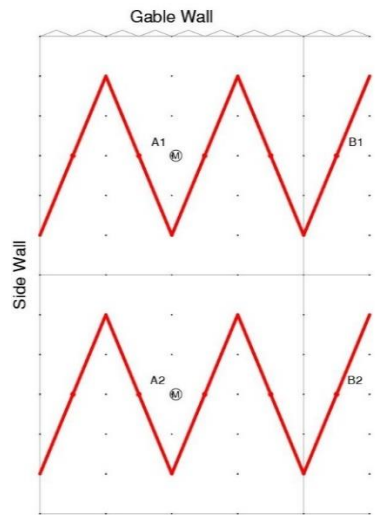

Determine on site the position of the bracing in the green area.



41.10.17



48.80.40



48.80.12



48.80.30



48.80.37

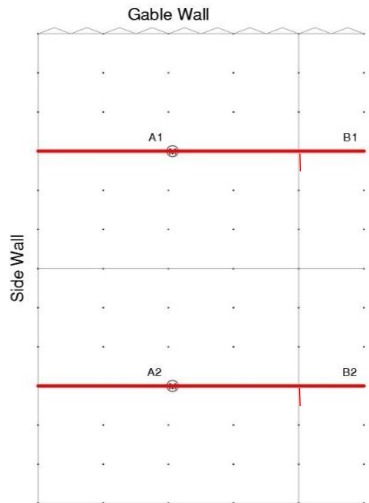

For tightening torque of the wire tensioner see chapter J.





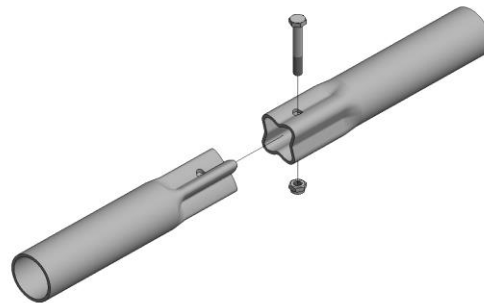



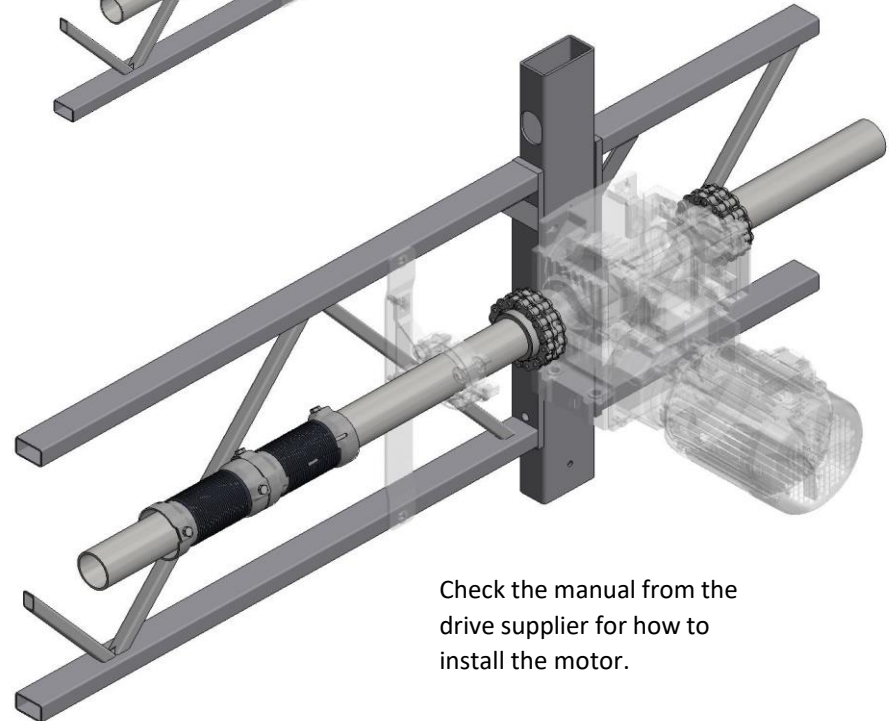

At the section separation use a end cap.

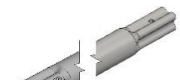

Attention: Slide the wire tensioner on the shaft before installing.

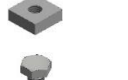

Check the manual from the drive supplier for how to install the motor.

-  50.42.06000
-  52.8--85---
-  52.8--86---
-  44.80.34-W
-  53.25.20 M8
-  55.40.16 M8x16
-  55.50.60 M10x60
-  55.50.05 M10
-  44.16.60

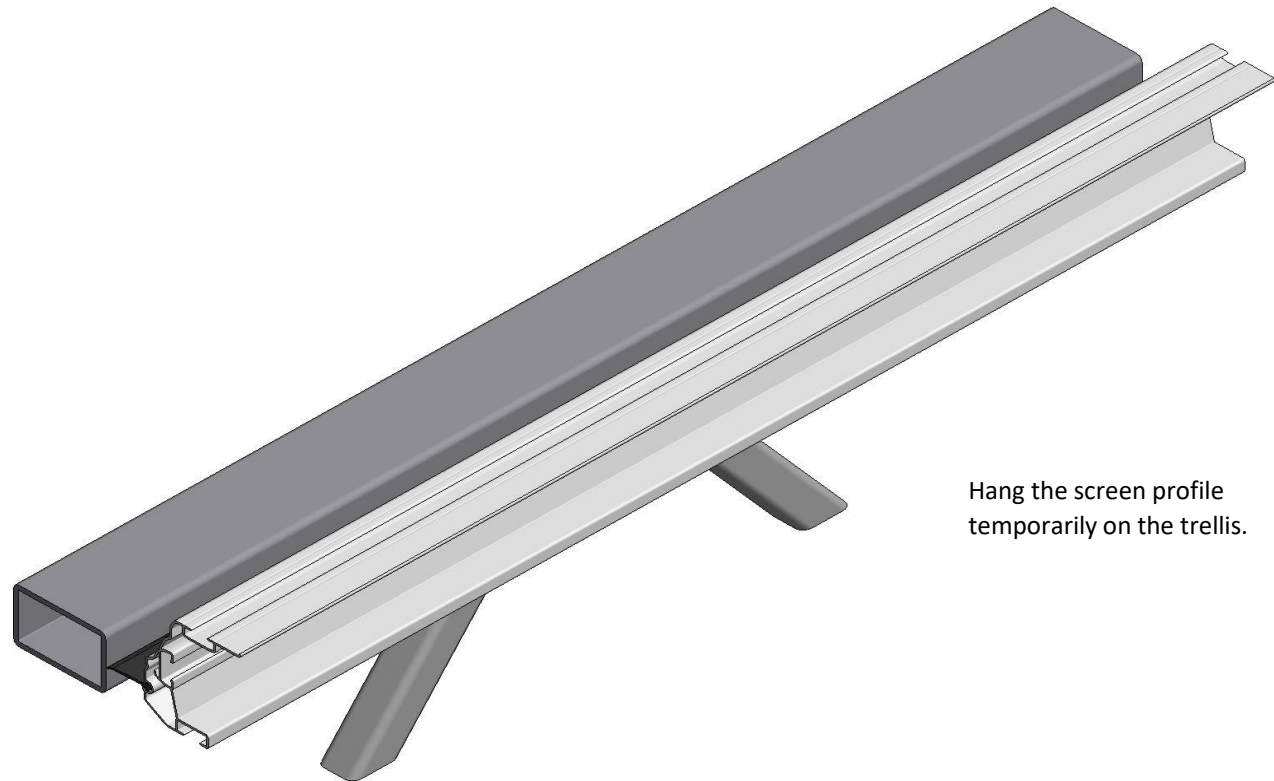
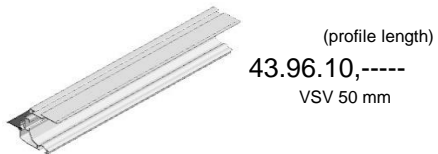
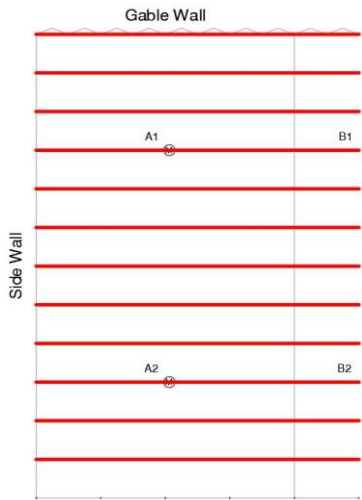

Hang the screen profile temporarily on the trellis.

► Polyester wires

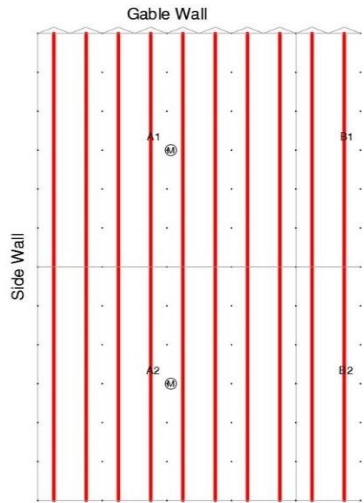

48.50.30

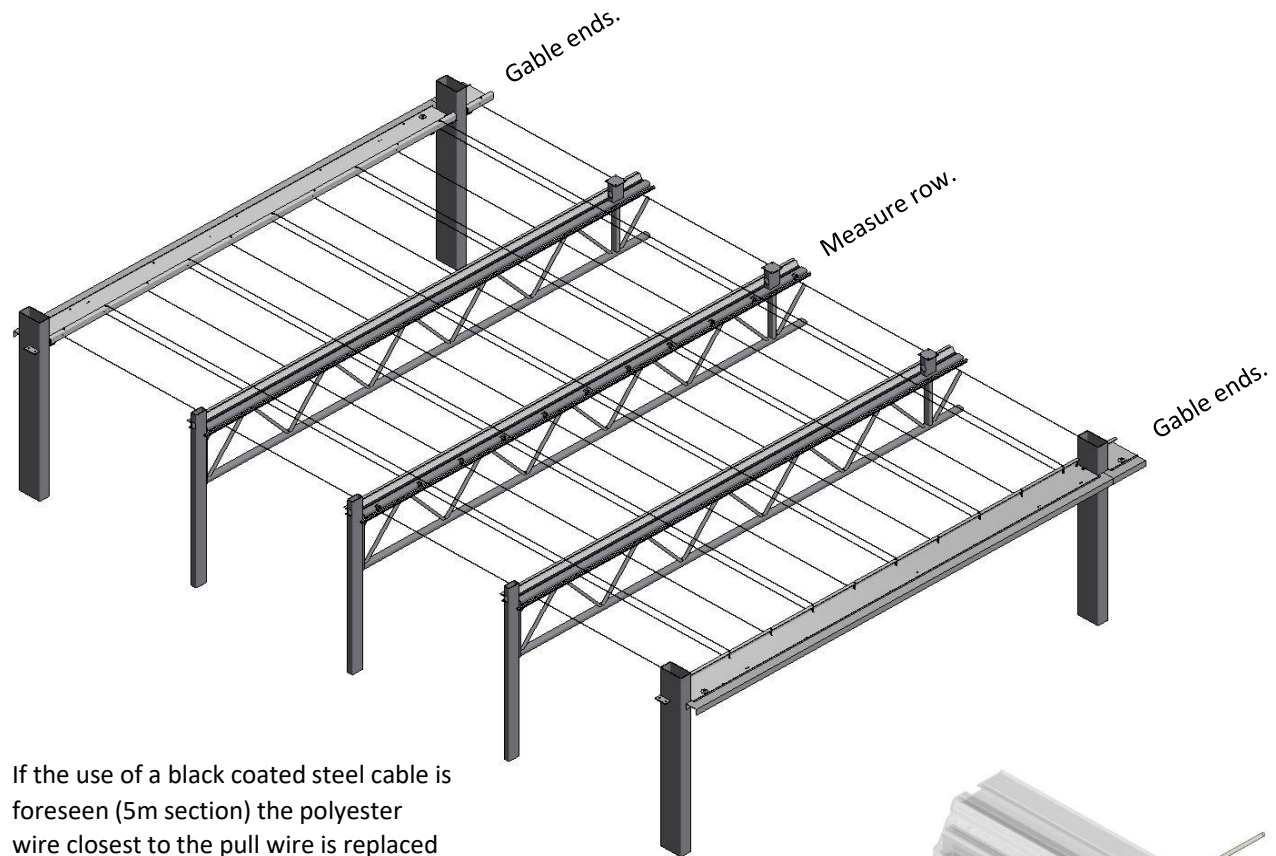

If the use of a black coated steel cable is foreseen (5m section) the polyester wire closest to the pull wire is replaced by this cable. (see next page)

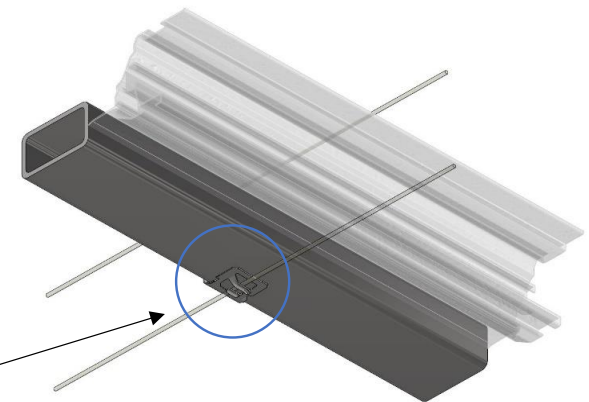

"Click" the polyester wire in the truss clip at the measure row.

▶ Extra black coated steel support cable

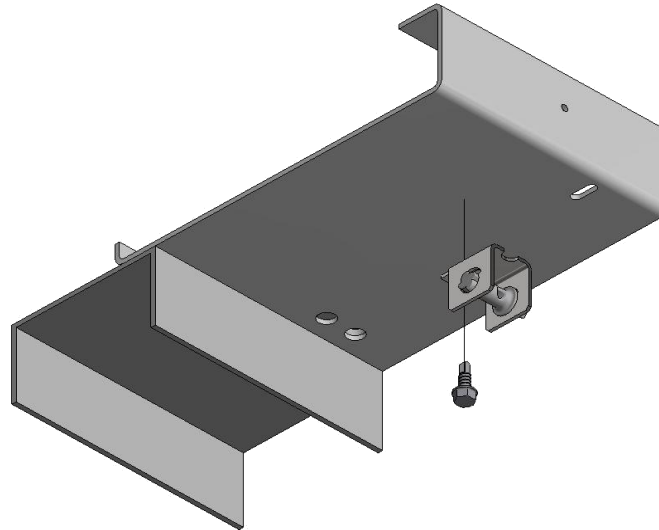
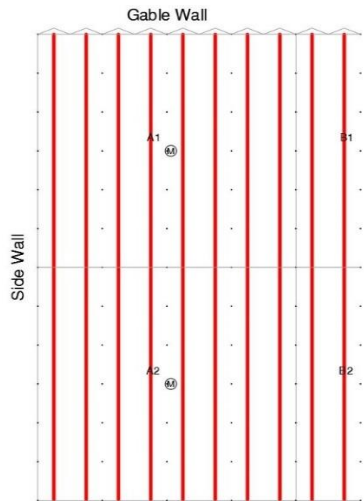

48.20.15



48.80.10



53.57.20

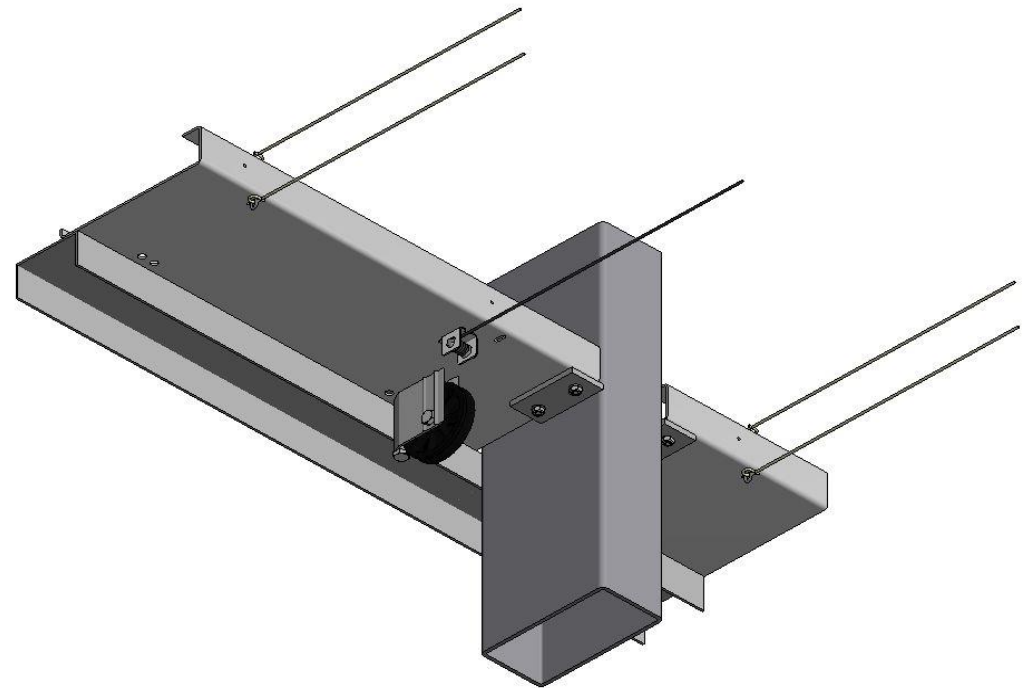

► Pull wire

Before mounting the wire on the wire tensioners make sure that everything on page G1 - G2 is clear and understood.

1.

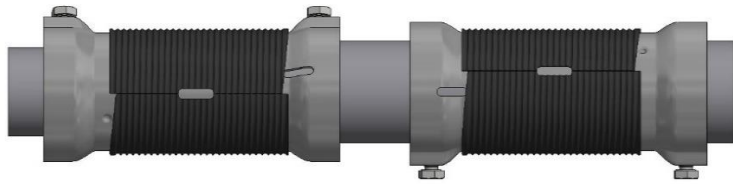

Make sure that the plastic cable drum is placed correctly. The plastic cable drum is correctly placed when the rectangular is aligned.

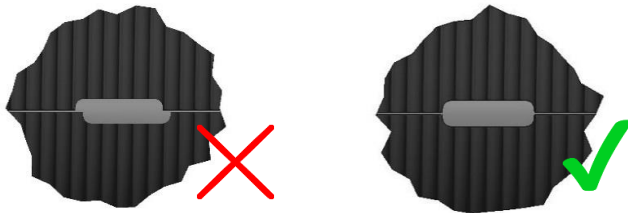

2. Make sure that the plastic cable drum is moved to the side where the knot will be placed, this to make sure there is enough space on the other side for the torque wrench.

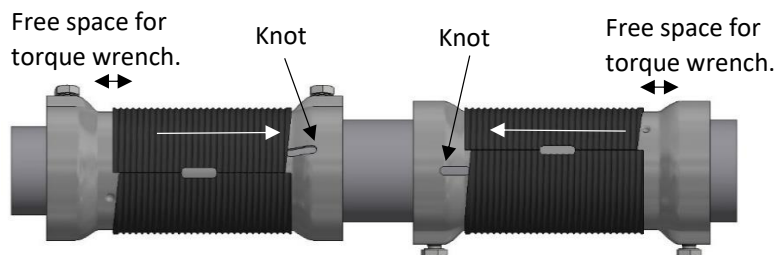

3. The holes in the plastic cable drum stand for how much wire needs to be on the wire tensioners at a certain section size.

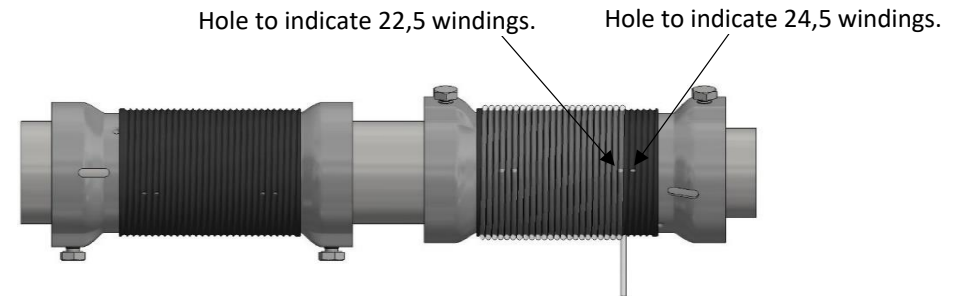

Bay size [mm]	No. of windings on wire tensioner 1	No. of windings on wire tensioner 2
3200	3,5	17,5
3658	3,5	19,5
4000	3,5	20,5
4500	3,5	22,5
5000	3,5	24,5

4. Tie a knot at the end of the wire and place the required number of windings on the ValkWireTensioner.

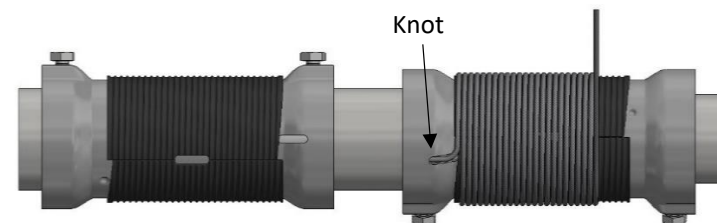

▶ Pull wire

5. Slide the ValkWireTensioners together in such a way that the knots are hidden between the tensioners.

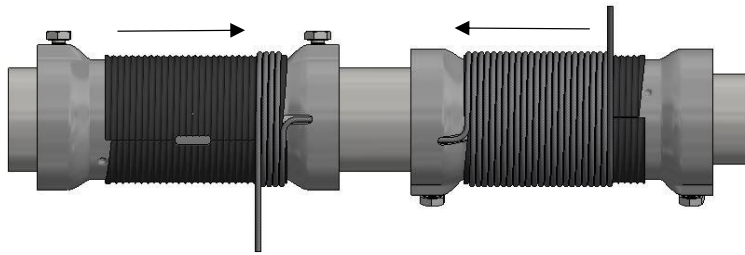

6. Finally, the wire should be wound on the ValkWireTensioner as shown in the picture below.



For the required wire tension, see page H3 and H4.

► Pull wire



Place the torque wrench 61.16.11 next to the ValkWireSleeve on the remaining piece of the ValkWireTensioner.



61.16.11



61.16.12



61.16.15

The tools listed above are optional and not standard provided with a screen system. You could order them at Van der Valk Systems.

For the required wire tension see page H4.

► Pull wire

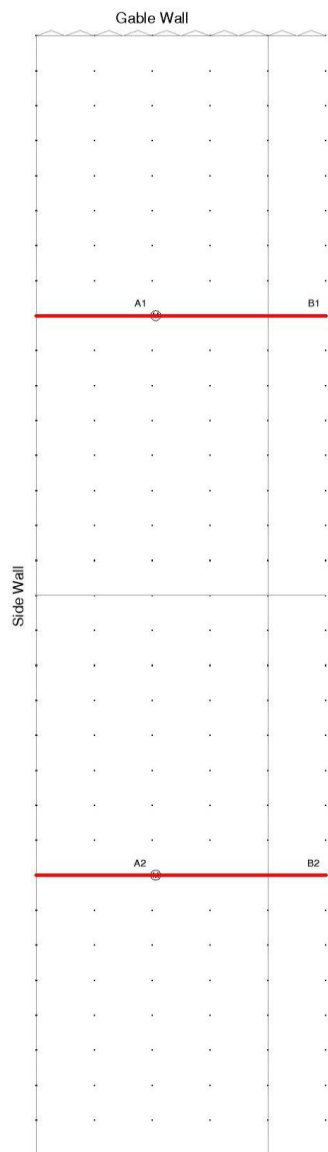

ValkKliMax green has a max. skid force of 3,5 kg.
 ValkKliMax blank has a max. skid force of 6 kg.
 ValkKliMax red has a max. skid force of 9 kg.

In the neutral position (= mounting position) there should be a certain pre-tension applied.
 This pre-tension is of great importance for the correct operation of the system.
 The pre-tension depends on the number of ValkKliMax's on one steel cable.

Calculated Cable tension [kg]	Moment to set on torque wrench [Nm]
40	20
50	25
60	30
80	40
100	50
130	60

$$\text{Cable pre-tension} = \frac{(\text{number of ValkKliMax's} \times \text{max. skid force})}{2} + 20 \text{ kg}$$

Example: See greenhouse on the left with 16 sections of a blank ValkKliMax.

$$\text{Cable pre-tension} = \frac{(16 \times 6 \text{ kg})}{2} + 20 \text{ kg} = 68 \text{ kg}$$

The torque wrench must be set approximately to 35 Nm. (see table)

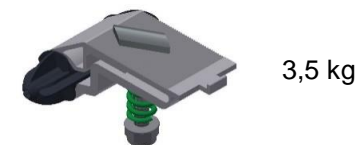

3,5 kg



6 kg



9 kg

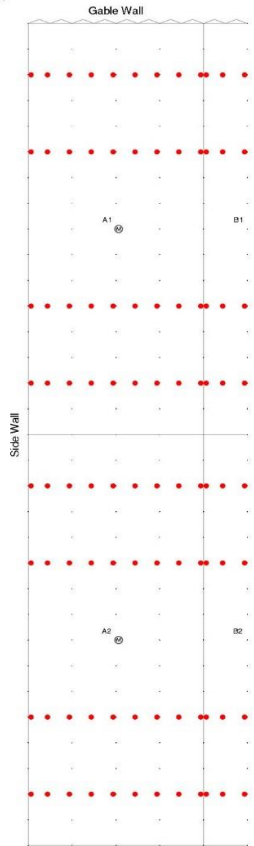

Mount the ValkPulley every 3rd section.



44.27.77

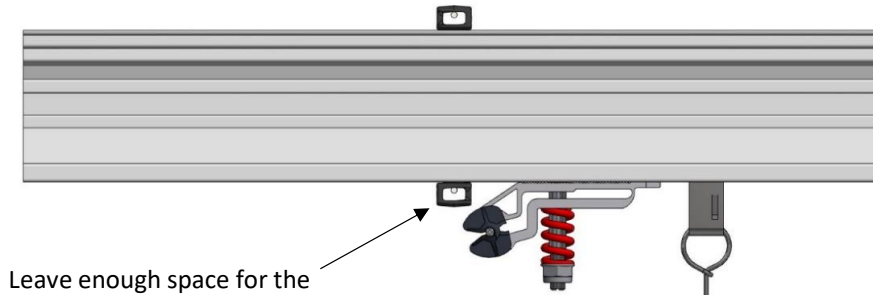

Leave enough space for the ValkWireGuide to slide.

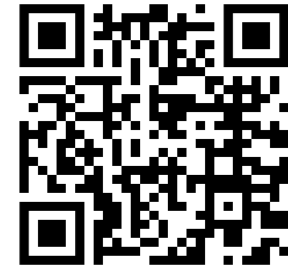
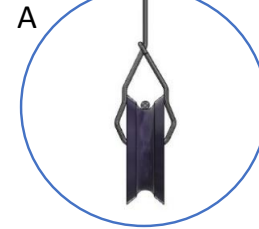

The return wire in the ValkPulley is designed to swing.

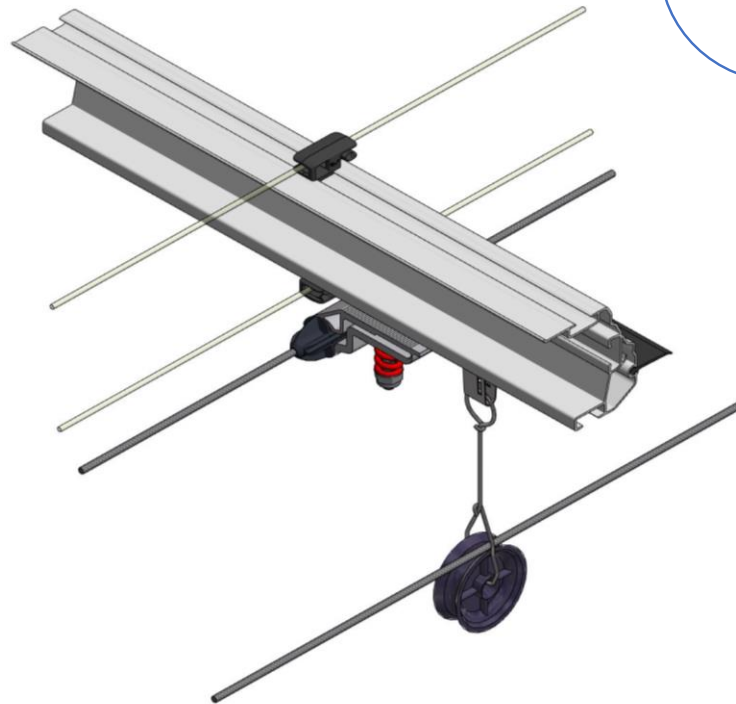

Detail A

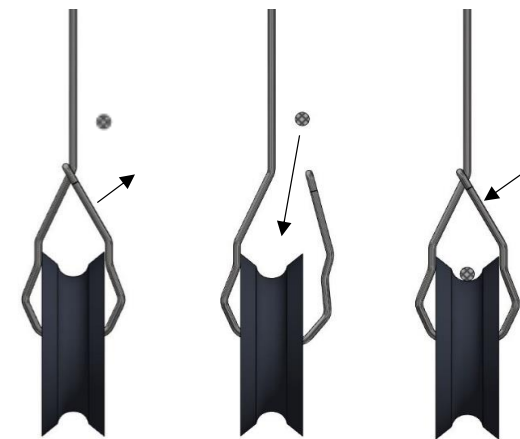

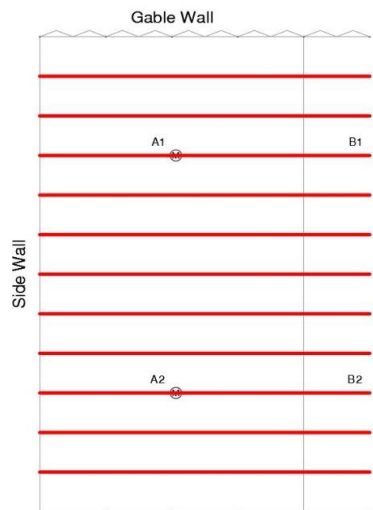

H + 2 mm
45.20.--



45.22.10

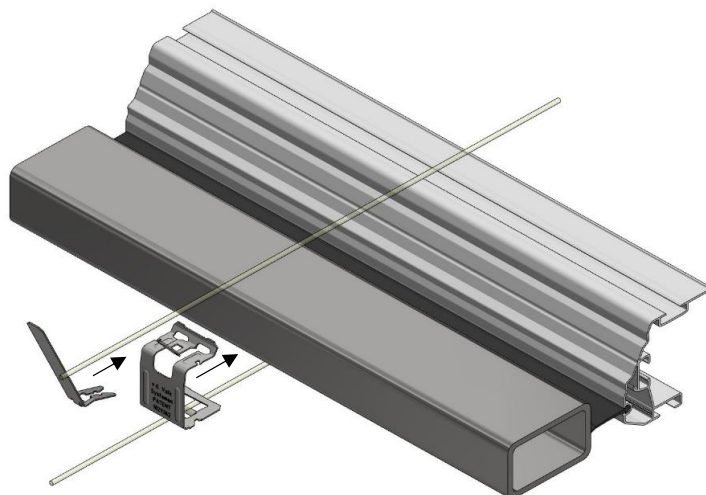

1. Slide the truss clip on the cord of the trellis
2. 'Click' the cloth stop finger on the truss clip.
3. Check if the stop finger is used every truss clip.

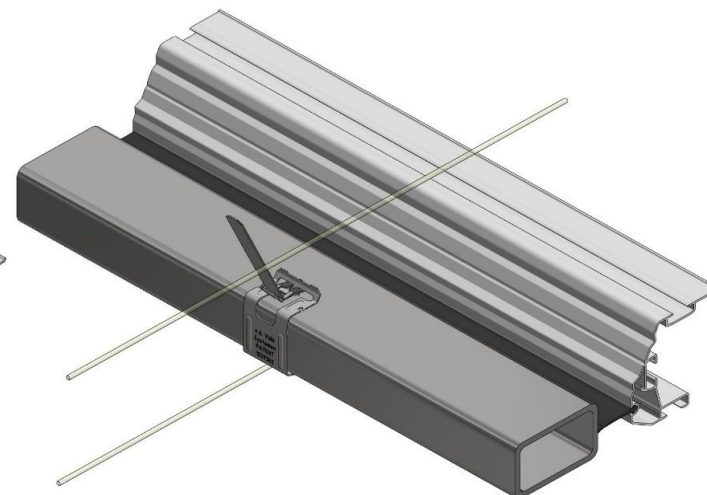

Note: Make sure the polyester wire is in the bottom of the truss clip.

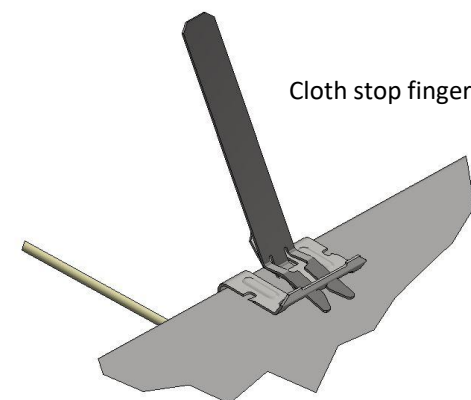
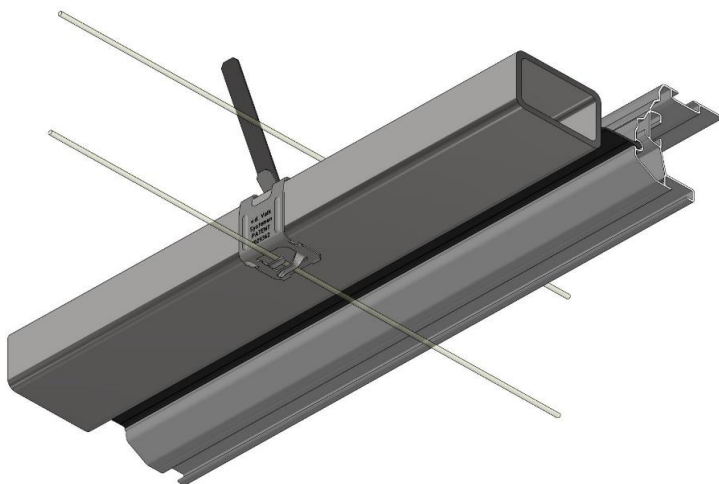

Cloth stop finger.

▶ Cloth pull rope

The rope you pull in, will later be used to pull in the screen cloth.

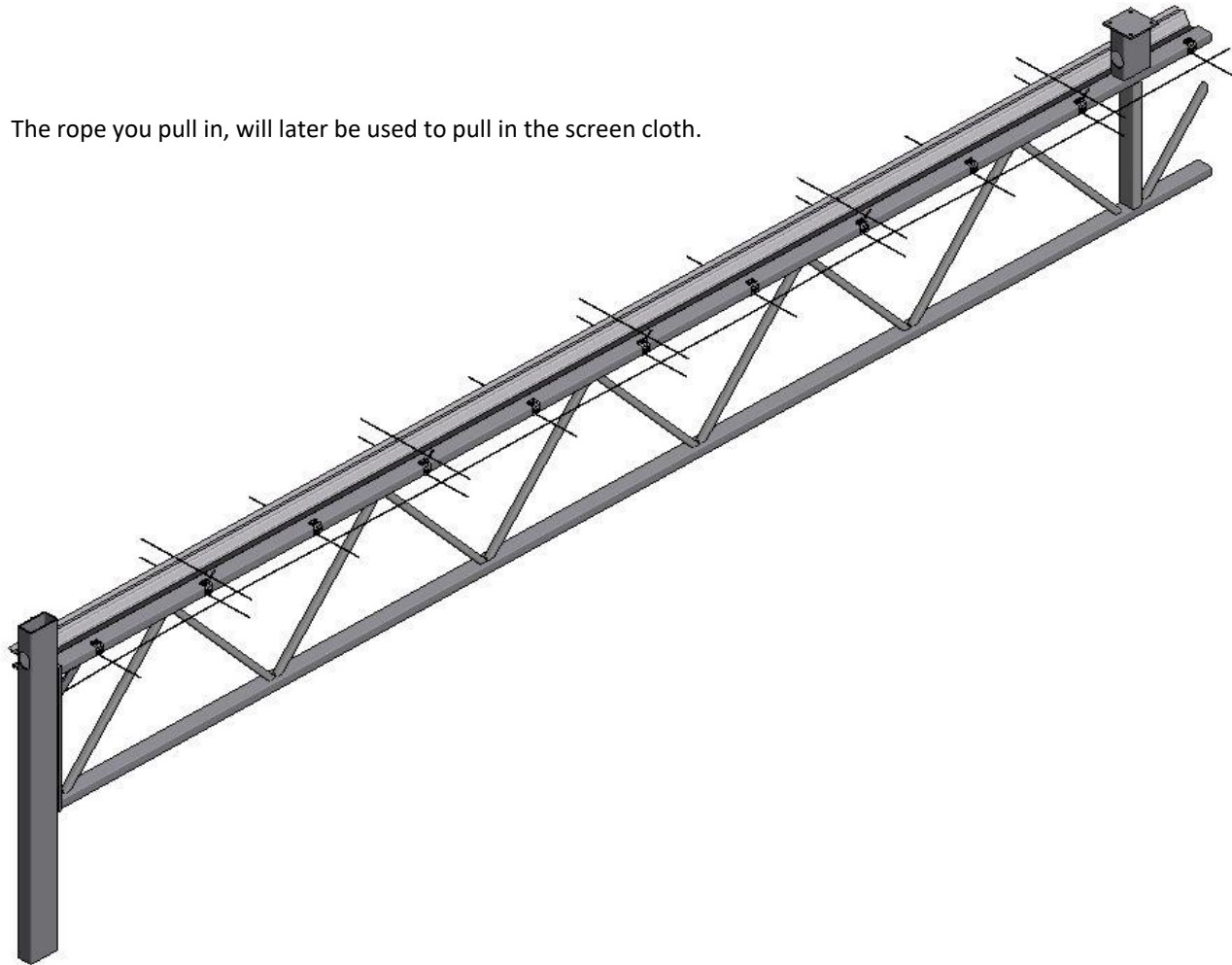

48.55.03

▶ ValkKliMax Slide

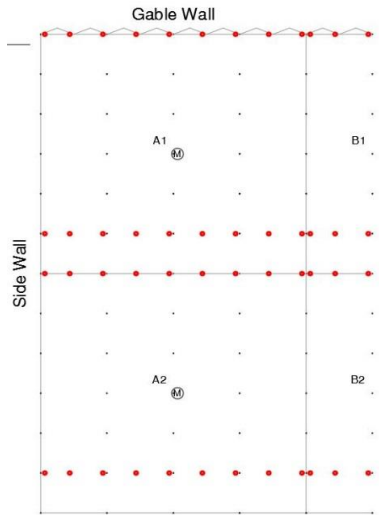

See project specific drawing for mounting the correct ValkKliMax Slide at the correct location!



- 44.40.44 (green spring)
- 44.40.45 (blank spring)
- 44.40.46 (red spring)



Attention:
Mount the ValkKliMax Slide before coupling the profiles.

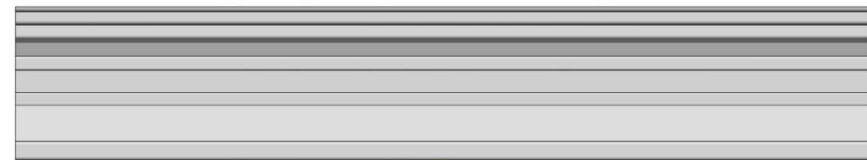

Attention:
Maximum tightening torque 6 Nm,
do NOT use an impact wrench.

Polyester wire.

Mount the ValkKliMax Slide with the head towards the polyester wire.

▶ Coupling ValkScreenVision profile

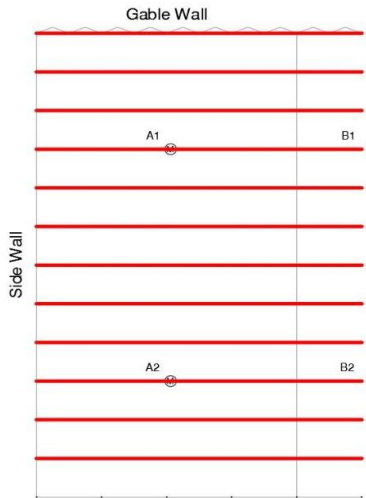

Attention:
Before coupling the profiles install the ValkKliMax Slide. See page L1.

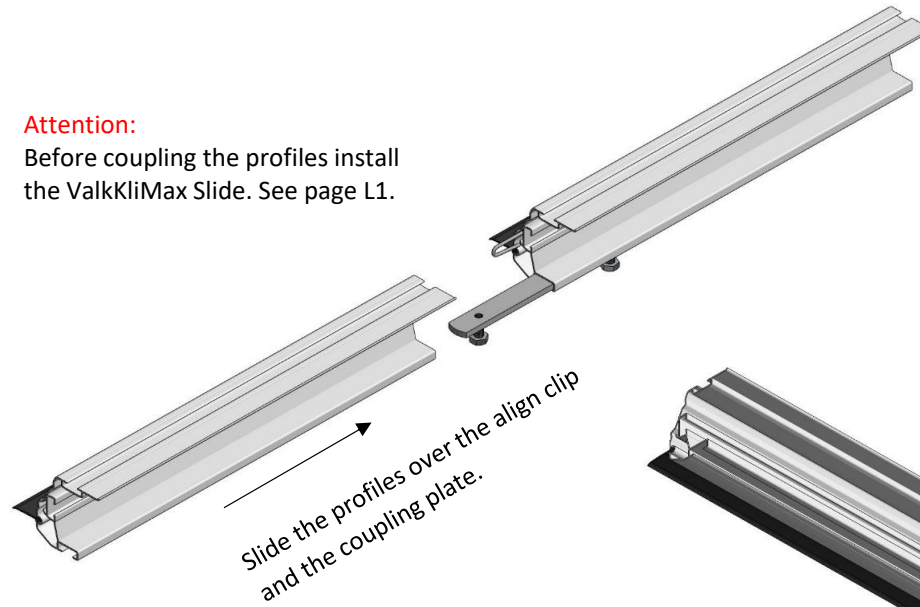

Attention:
For the profile sequence see page E1 or the project specific drawing.

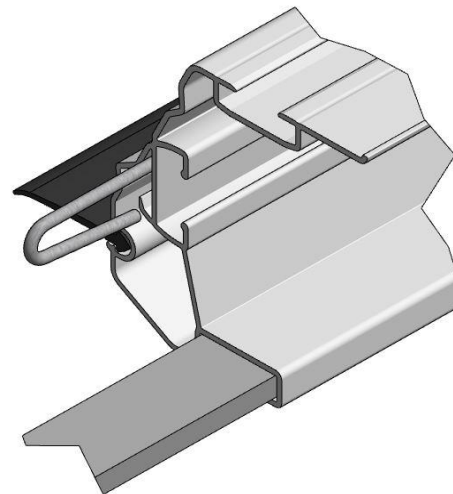

The align clip is mounted for a perfect alignment of the VSV chamber in the VSV profiles.

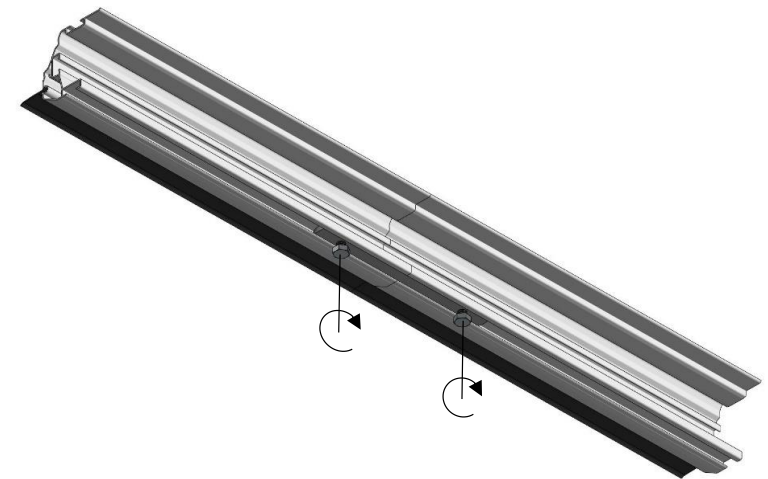

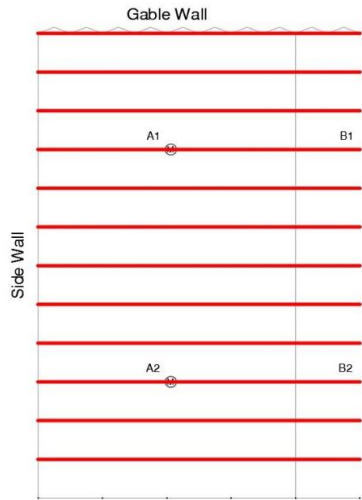

44.15.27

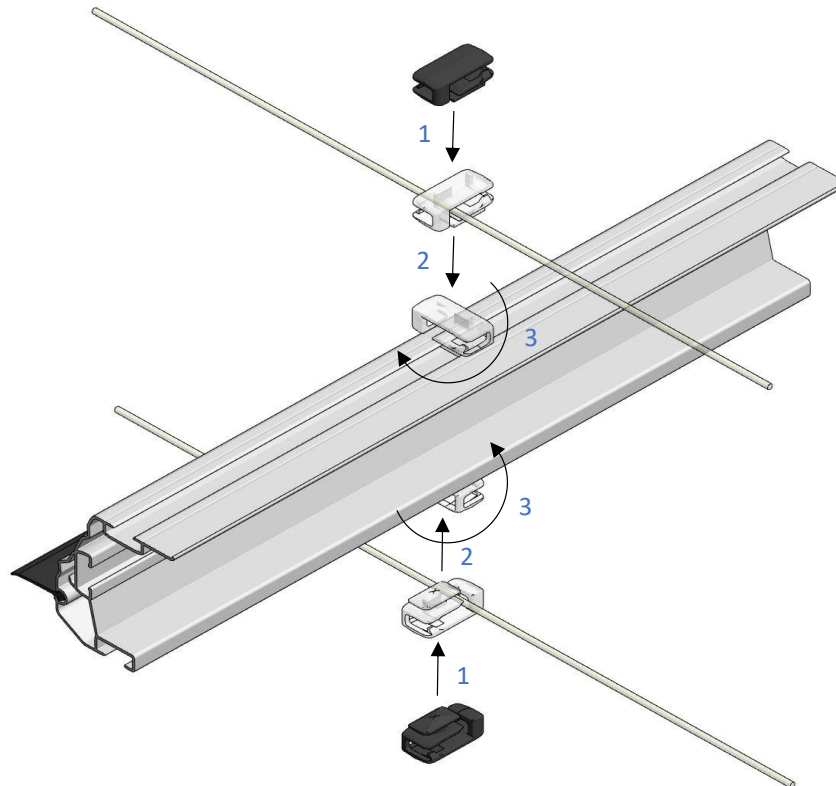

1. Slide the wire guide block on the polyester wire.
2. Insert the wire guide block in de profile chamber.
3. Turn the wire guide block until the wire 'clicks' in the wire guide block, make sure the opening is on the correct side, see the pictures on the right.

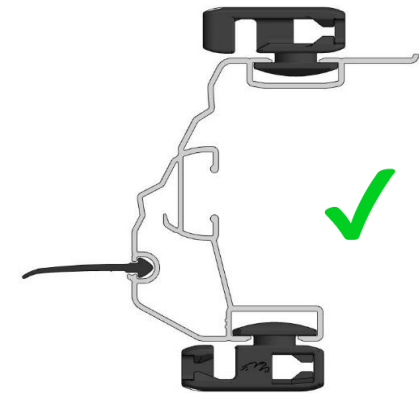

Mount the wire guide blocks with the opening as shown.

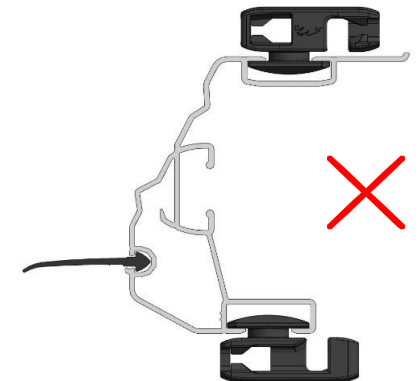

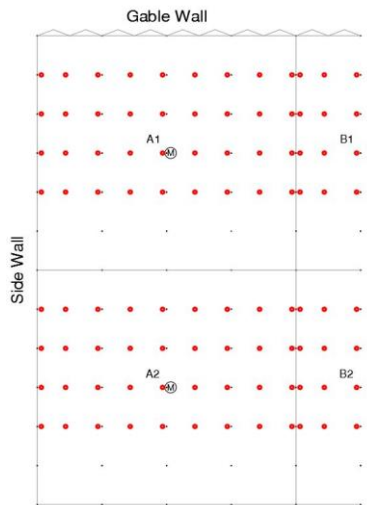

See project specific drawing for mounting the correct ValkKliMax at the correct location!

The ValkKliMax in the sections next to the reversing wheel are slidable. The side wall ValkKliMax's are red spring ValkKliMax's.



- 44.40.34 (green spring)
- 44.40.35 (blank spring)
- 44.40.36 (red spring)

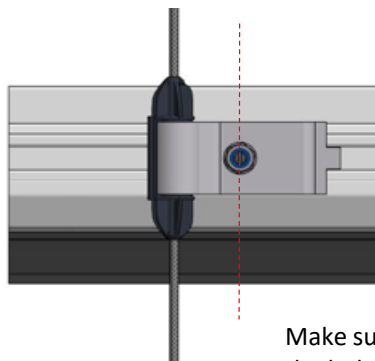
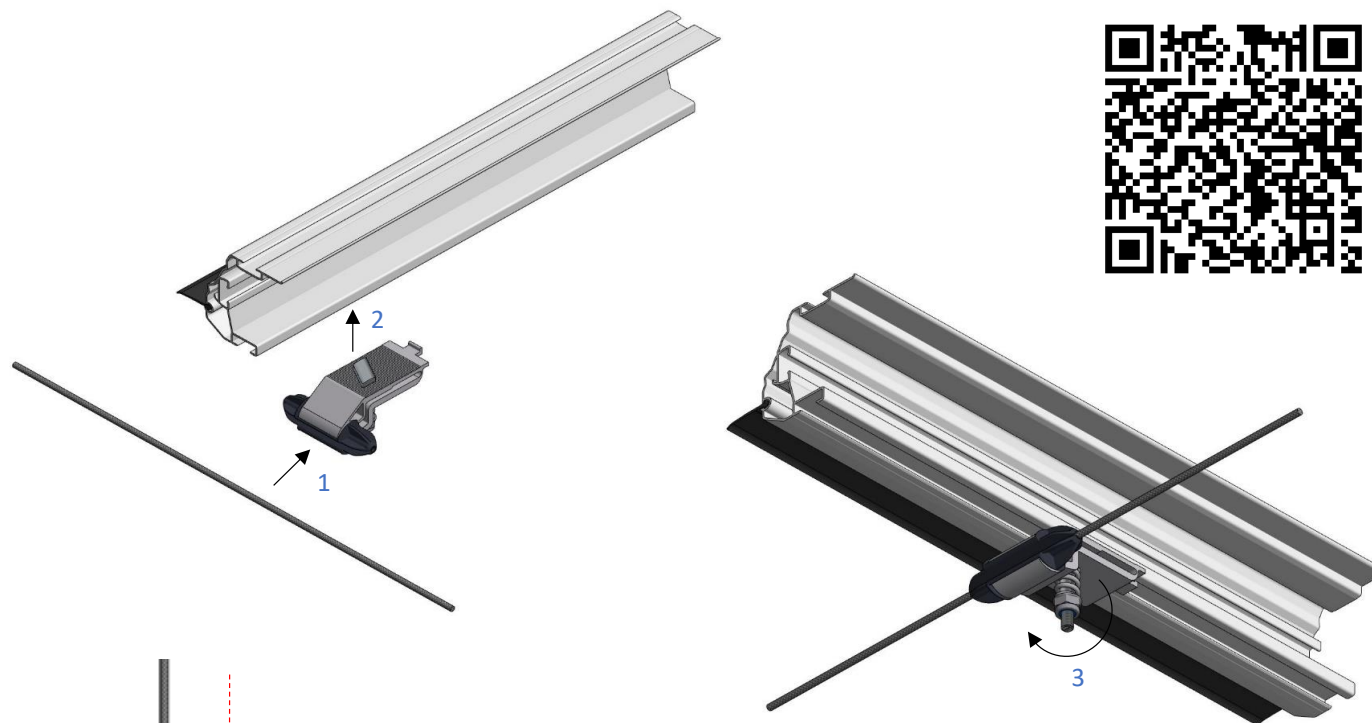

Make sure that the line on the bottom of the bolt is parallel to the cable.

1. 'Click' the pull wire in the ValkKliMax.
2. Mount the ValkKliMax in the profile chamber.
3. Tighten the bolt with a maximum torque of 6 N/m, do NOT use an impact wrench.

▶ Attachment of cloth to ValkScreenProfile and trusses

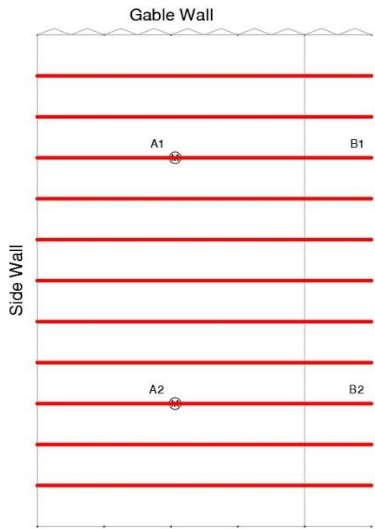

44.15.42

Retract the screen cloth according to the regulations from your cloth supplier.

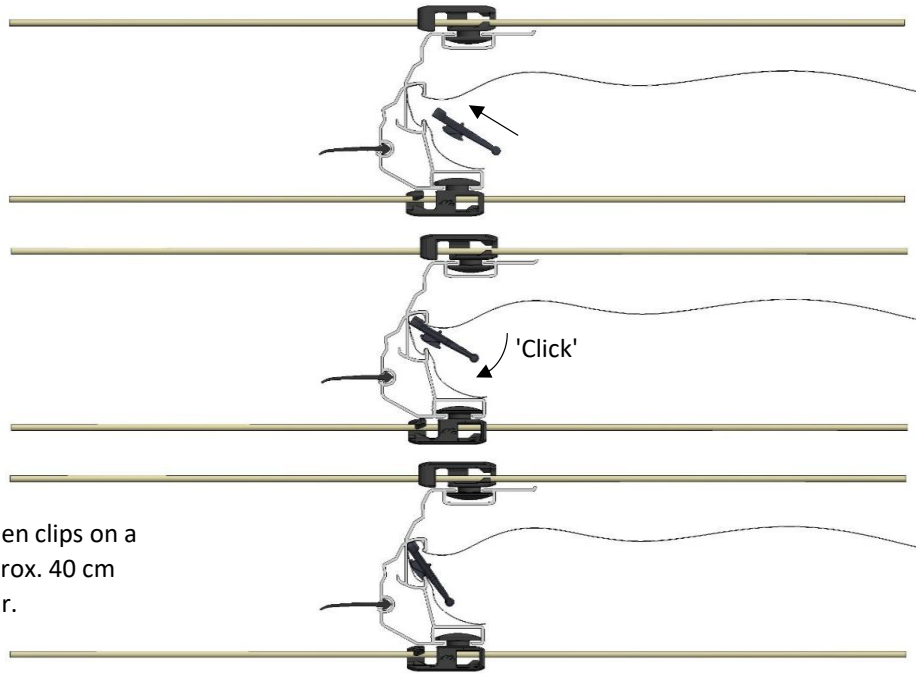

Mount the screen clips on a distance of approx. 40 cm from each other.

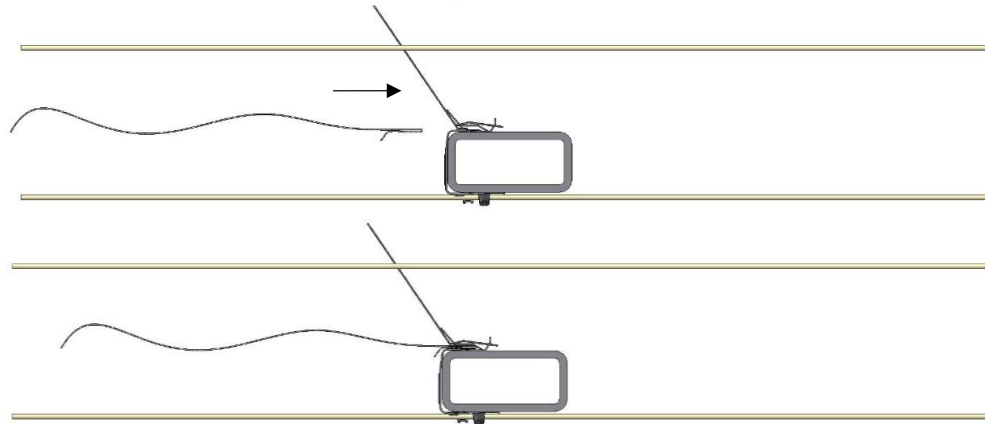

To attach the cloth to the truss clips, use for example a flexible putty knife.

▶ Cloth hangdown - VSV

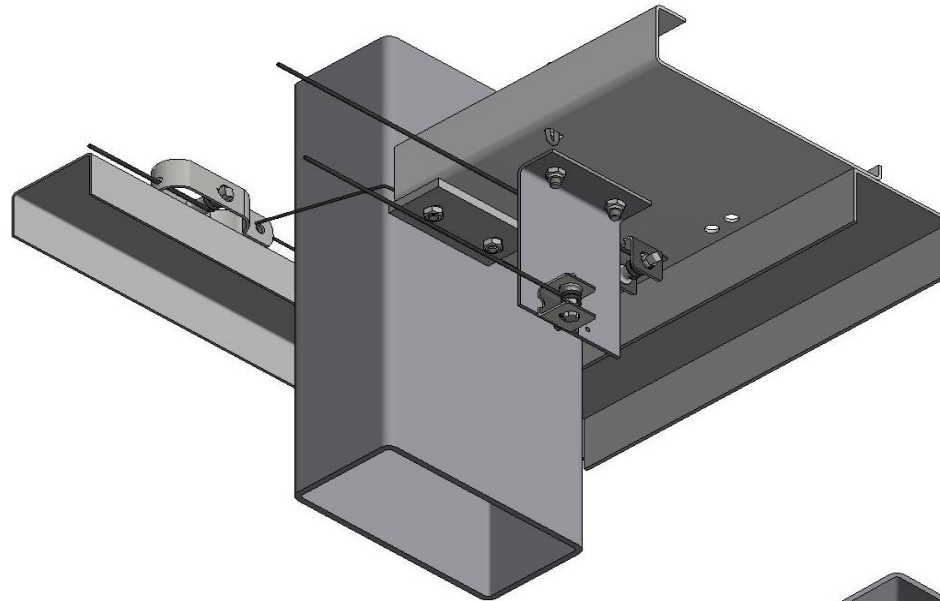
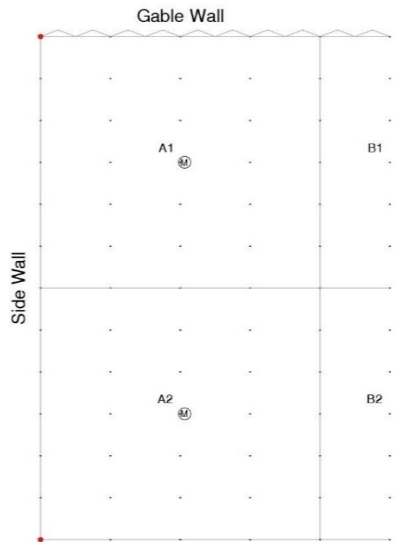

	44.84.25	
	55.40.20	M8x20
	55.40.05	M8
	44.80.10	
	55.30.16	M6x16
	55.30.00	M6
	48.20.15	
	48.80.12	

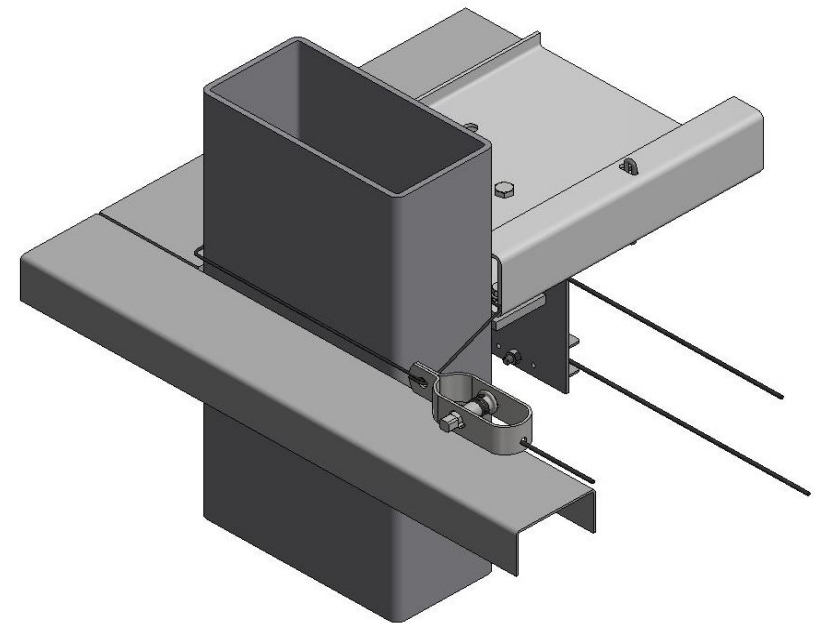

▶ Cloth hangdown - VSV

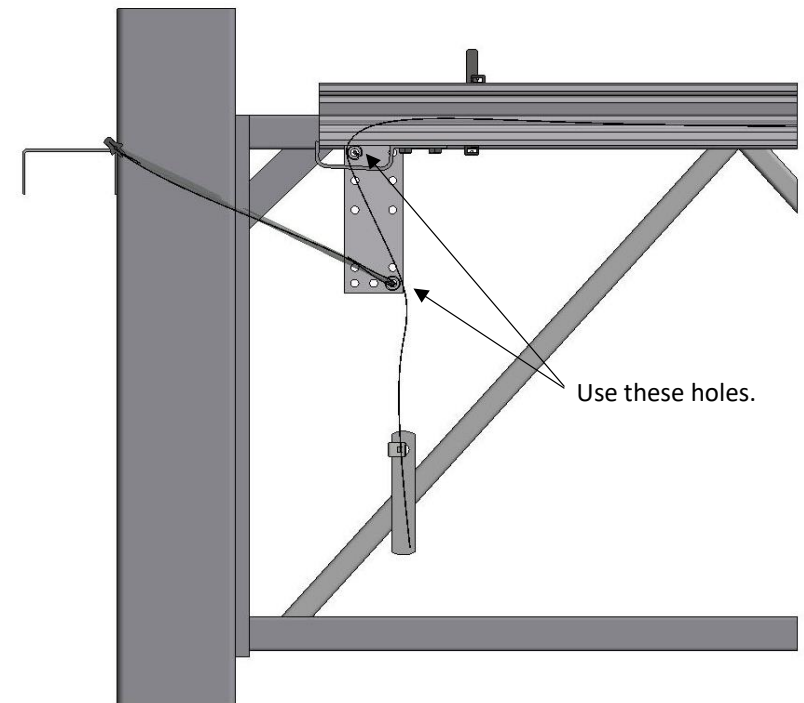
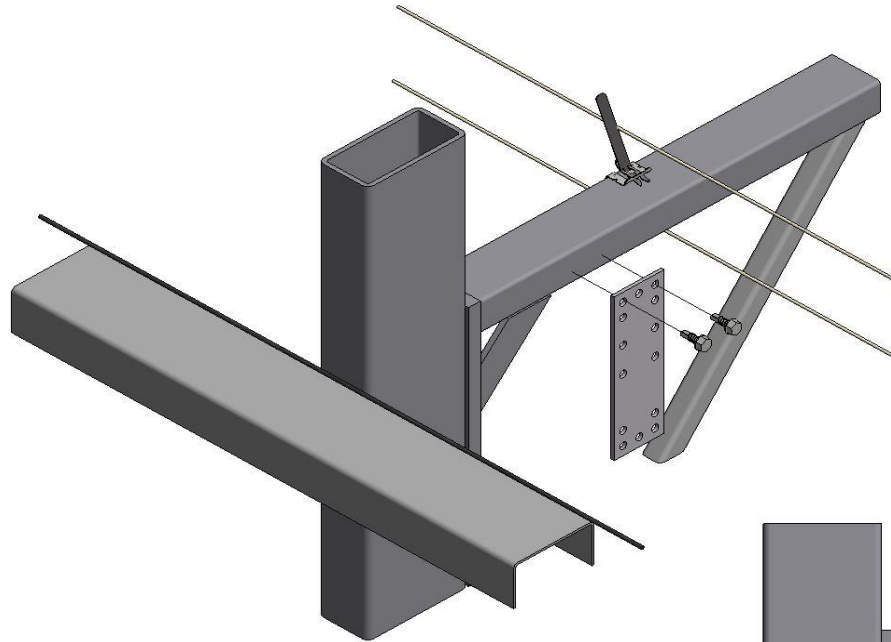
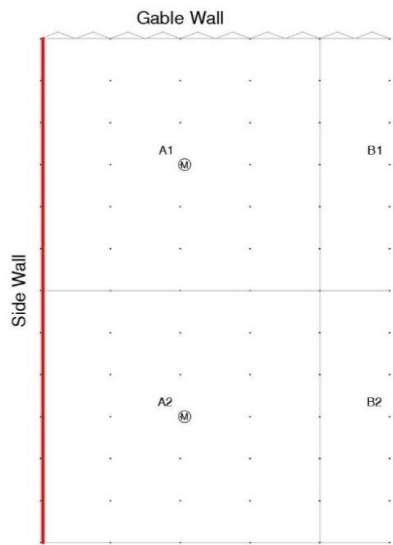

44.27.15



53.57.20

▶ Cloth hangdown - VSV

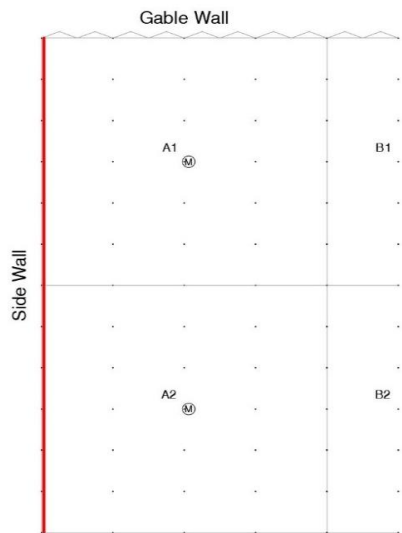

44.17.17 VSV 22

44.17.18 VSV 35



55.20.16

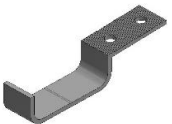

44.27.05



44.05.05



55.30.10

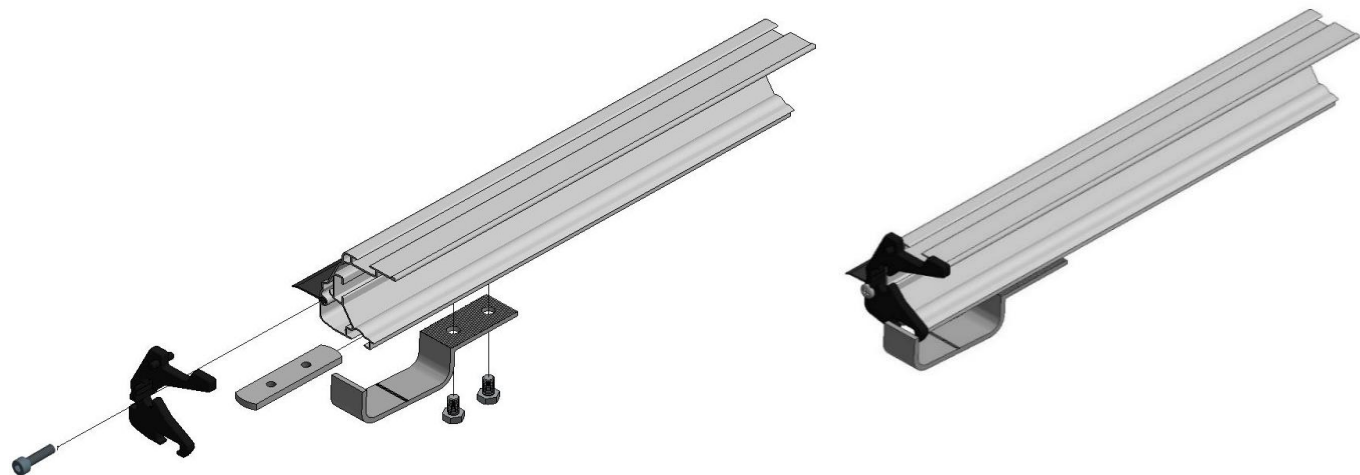

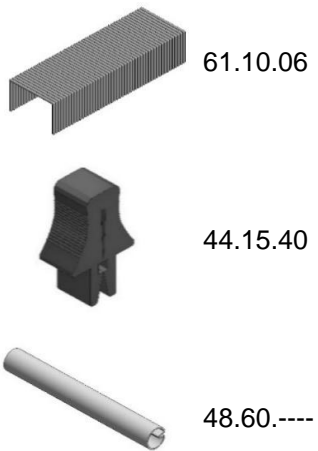
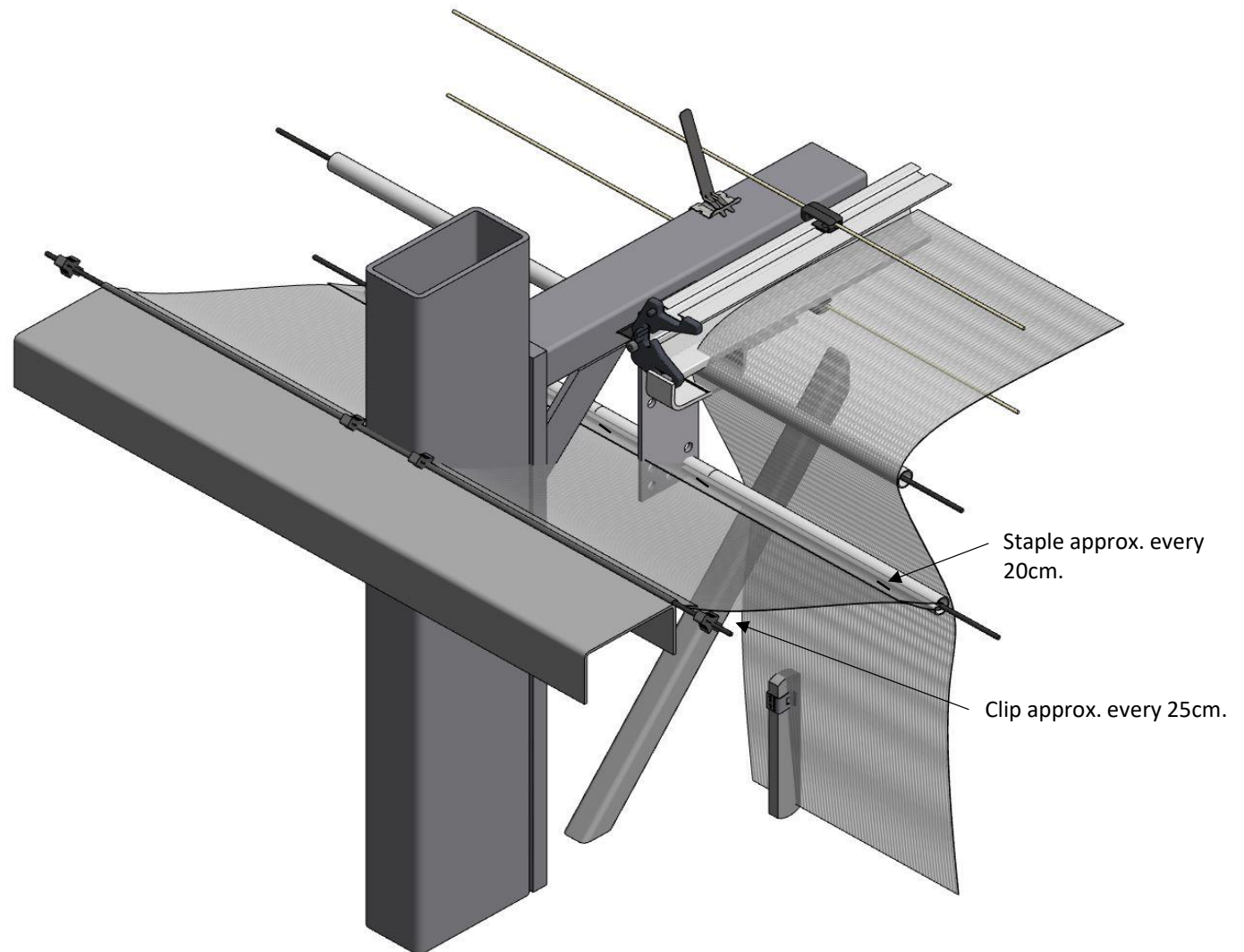
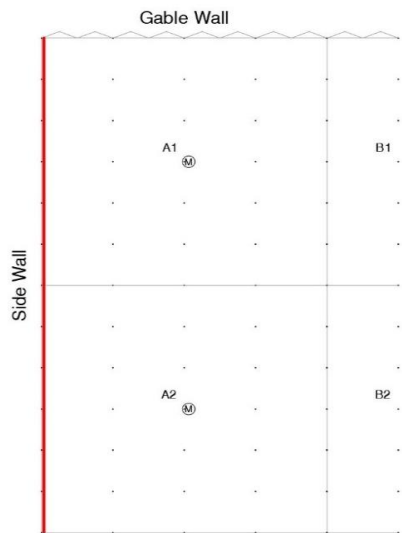

▶ Cloth hangdown - Fixed cloth - Side wall

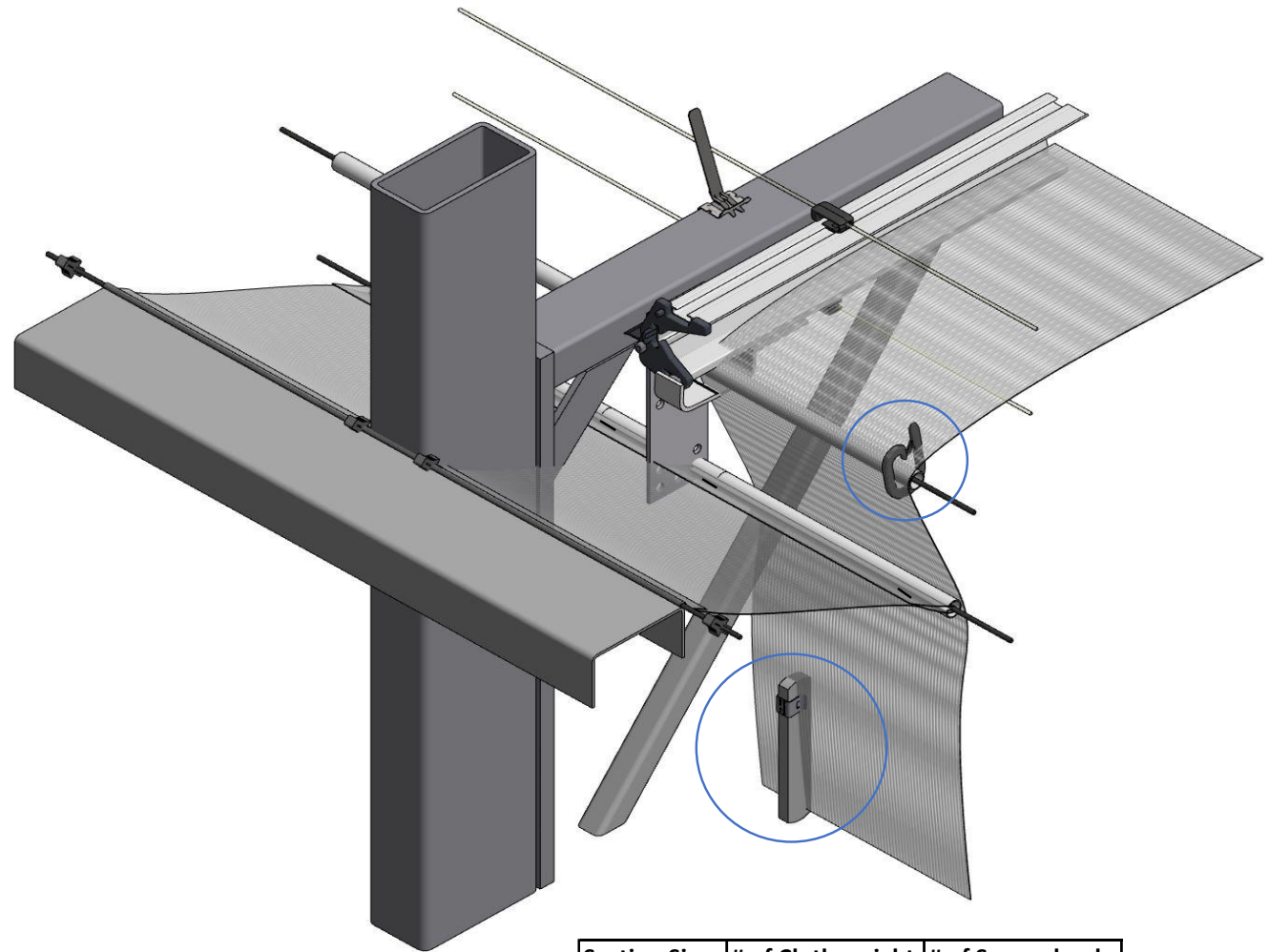
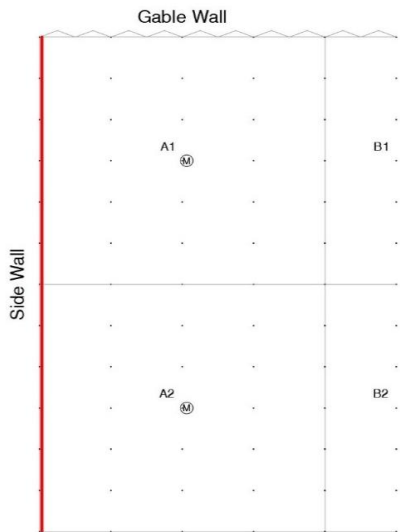

▶ Cloth hangdown - Fixed cloth - Side wall



-  44.70.25
-  45.45.50
-  44.15.20

Section Size	# of Cloth weight	# of Screen hook
3658	5	7
4000	6	8
4500	7	9
5000	8	10